

330 B CNC

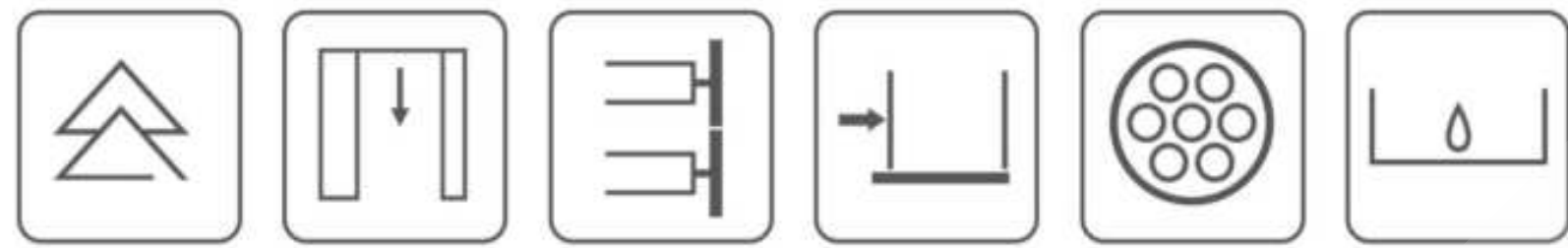

CUTTING CAPACITY MM	BLADE SIZE MM	BLADE SPEED M/MIN	MAIN MOTOR KW	COOLING MOTOR W	HYDRAULIC MOTOR KW	MACHINE SIZE (L*W*H) MM	WEIGHT KG
330X330	35x1.3x4115	10-80	4	90	0.75	2200*2100*1500	1800

360B CNC

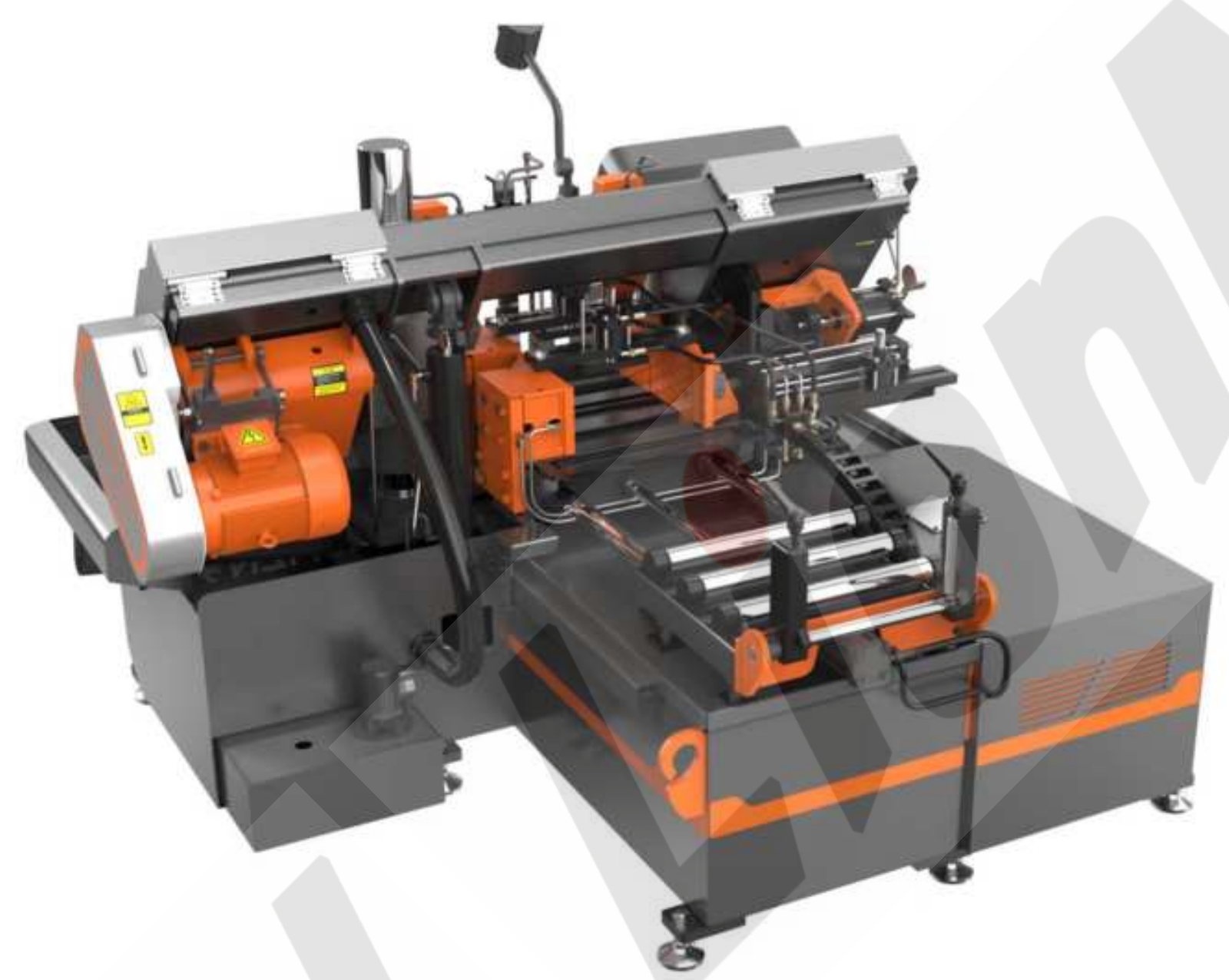
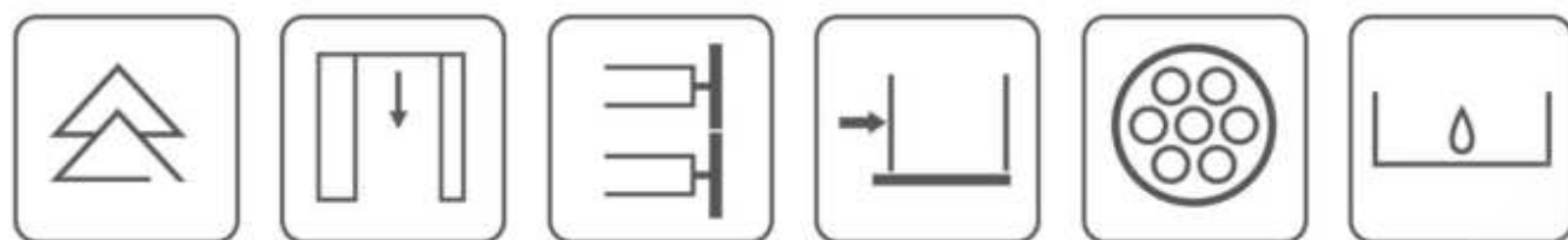

CUTTING CAPACITY MM	BLADE SIZE MM	BLADE SPEED M/MIN	MAIN MOTOR KW	COOLING MOTOR W	HYDRAULIC MOTOR KW	MACHINE SIZE (L*W*H) MM	WEIGHT KG
360 *360	1.1*34*4400	10-80	5.5	90	0.75	2400*2100*1500	2000

430 B CNC

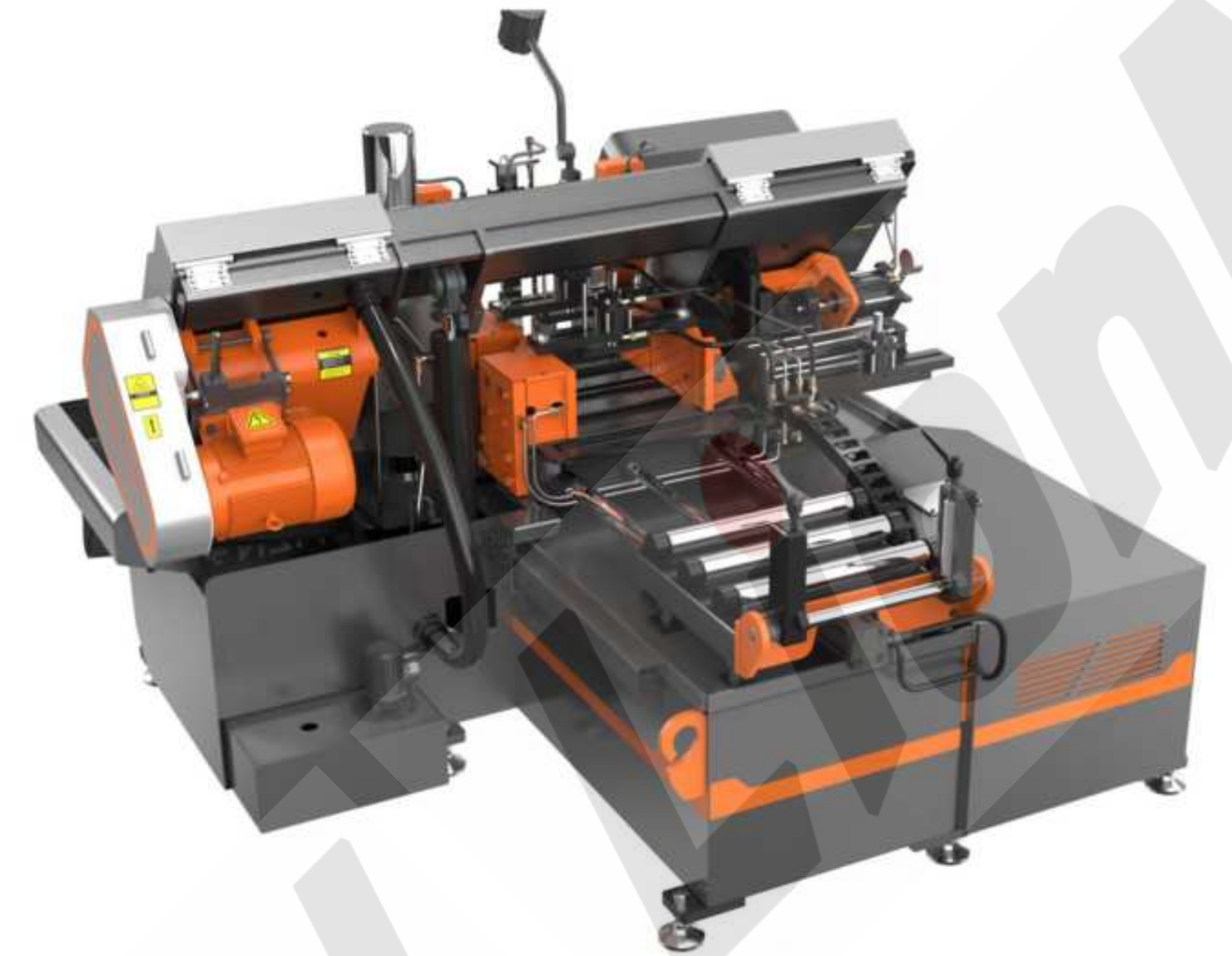
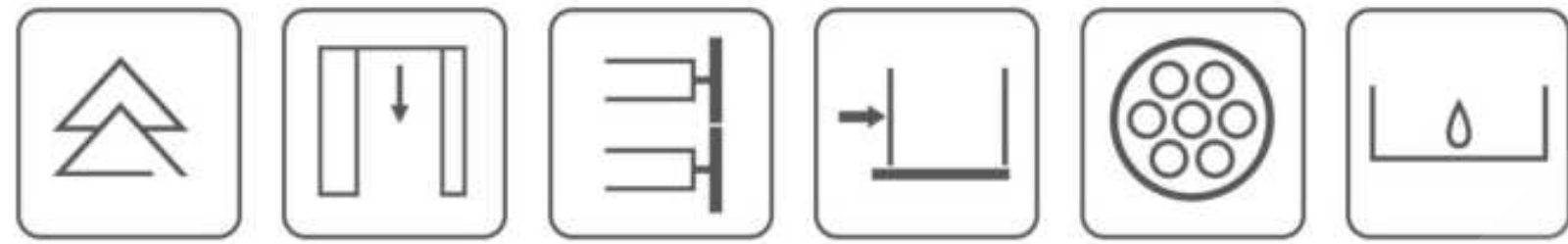

CUTTING CAPACITY MM	BLADE SIZE MM	BLADE SPEED M/MIN	MAIN MOTOR KW	COOLING MOTOR W	HYDRAULIC MOTOR KW	MACHINE SIZE (L*W*H) MM	WEIGHT KG
430X430	41x1.3x5100	10-80	5.5	90	1.5	2800*2200*1750	3200

530 B CNC

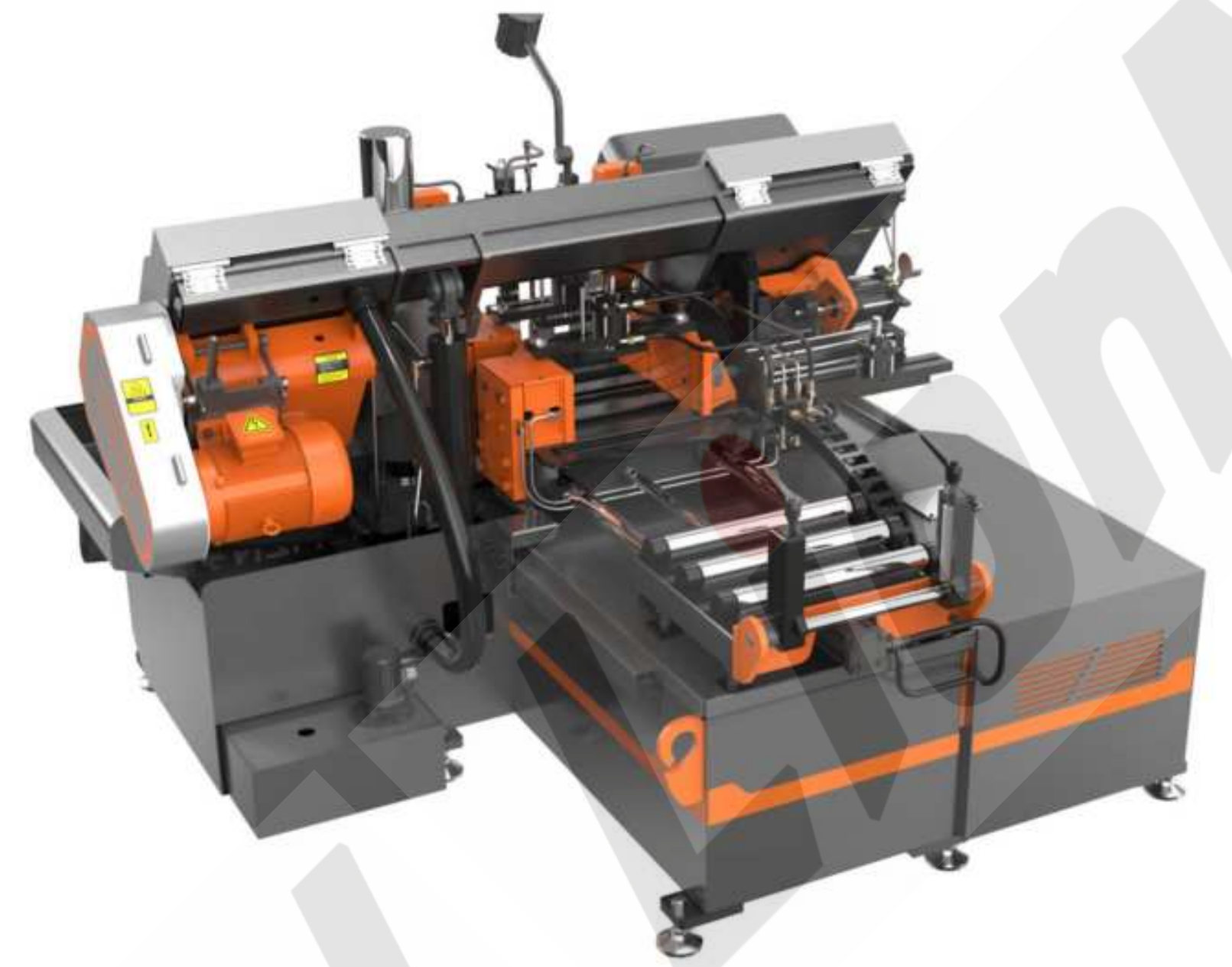
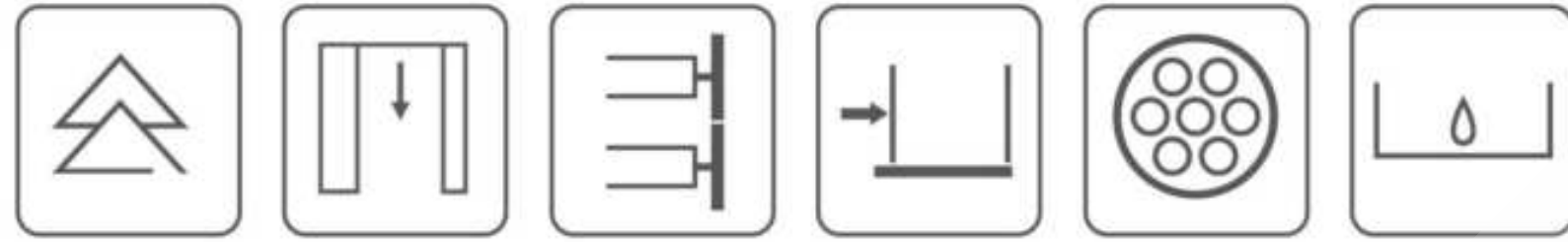

CUTTING CAPACITY MM	BLADE SIZE MM	BLADE SPEED M/MIN	MAIN MOTOR KW	COOLING MOTOR W	HYDRAULIC MOTOR KW	MACHINE SIZE (L*W*H) MM	WEIGHT KG
530X530	41x1.3x6050	10-80	7.5	135	1.5	3100*2200*2000	4100

BSV8052CNC

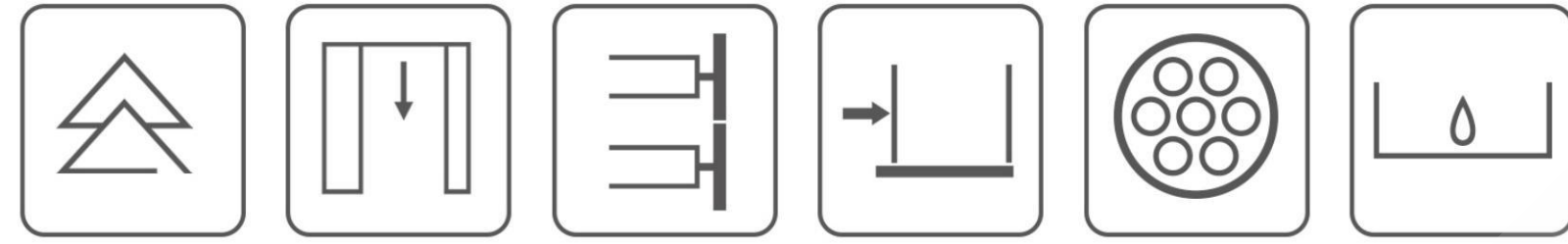

CUTTING CAPACITY MM	BLADE SIZE MM	BLADE SPEED M/MIN	MAIN MOTOR KW	COOLING MOTOR W	HYDRAULIC MOTOR KW	MACHINE SIZE (L*W*H) MM	WEIGHT KG
800*520	54*1.6mm	10-70	11	1000	2.25	3900X2750X2550	7000

CUTTING CAPACITY MM	BLADE SIZE MM	BLADE SPEED M/MIN	MAIN MOTOR KW	COOLING MOTOR W	HYDRAULIC MOTOR KW	MACHINE SIZE (L*W*H) MM	WEIGHT KG
1000*650	1.6*67	10-70	15	1000	2.25	4500*2900*2950	10000

BSV100/65

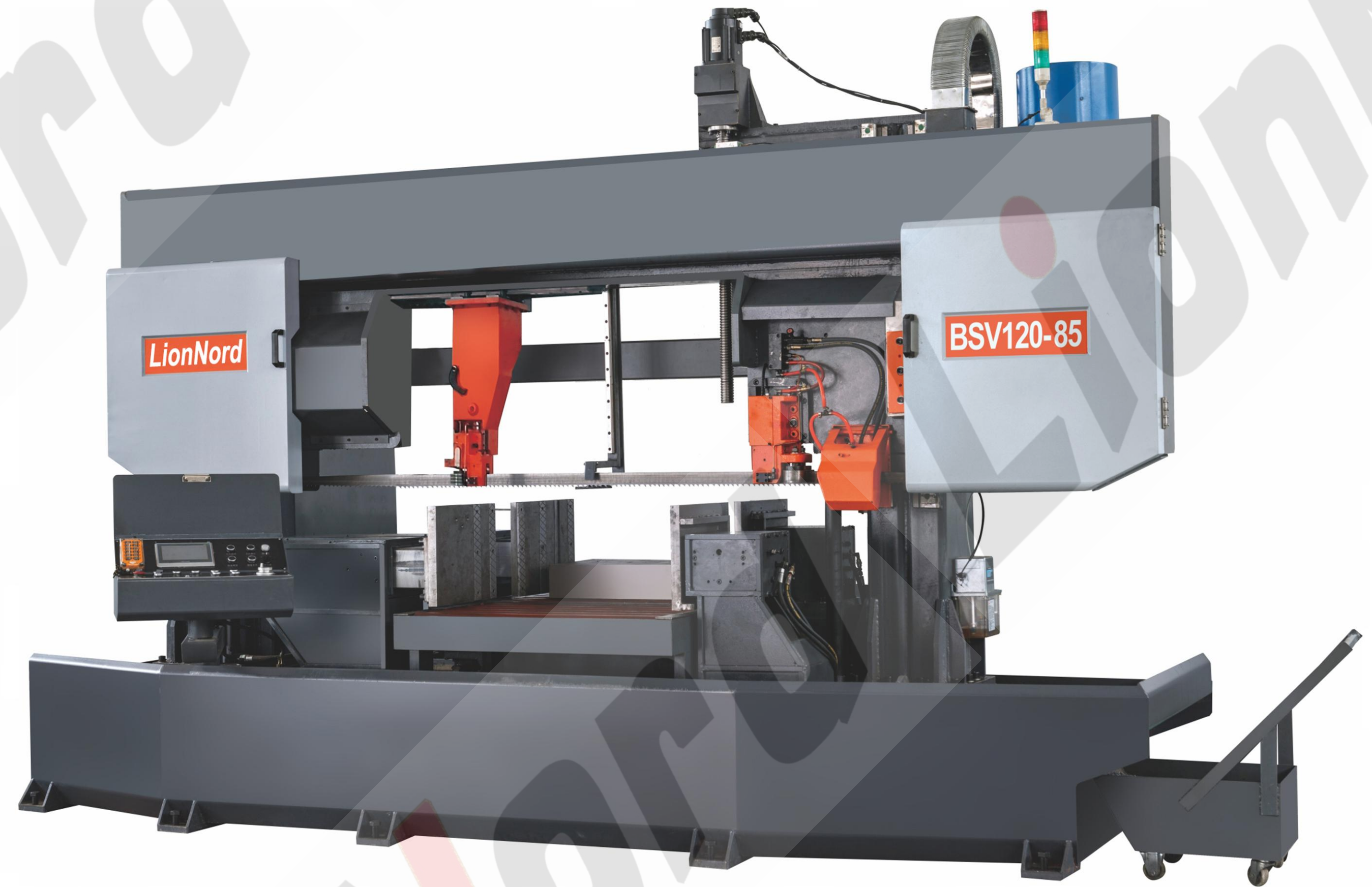
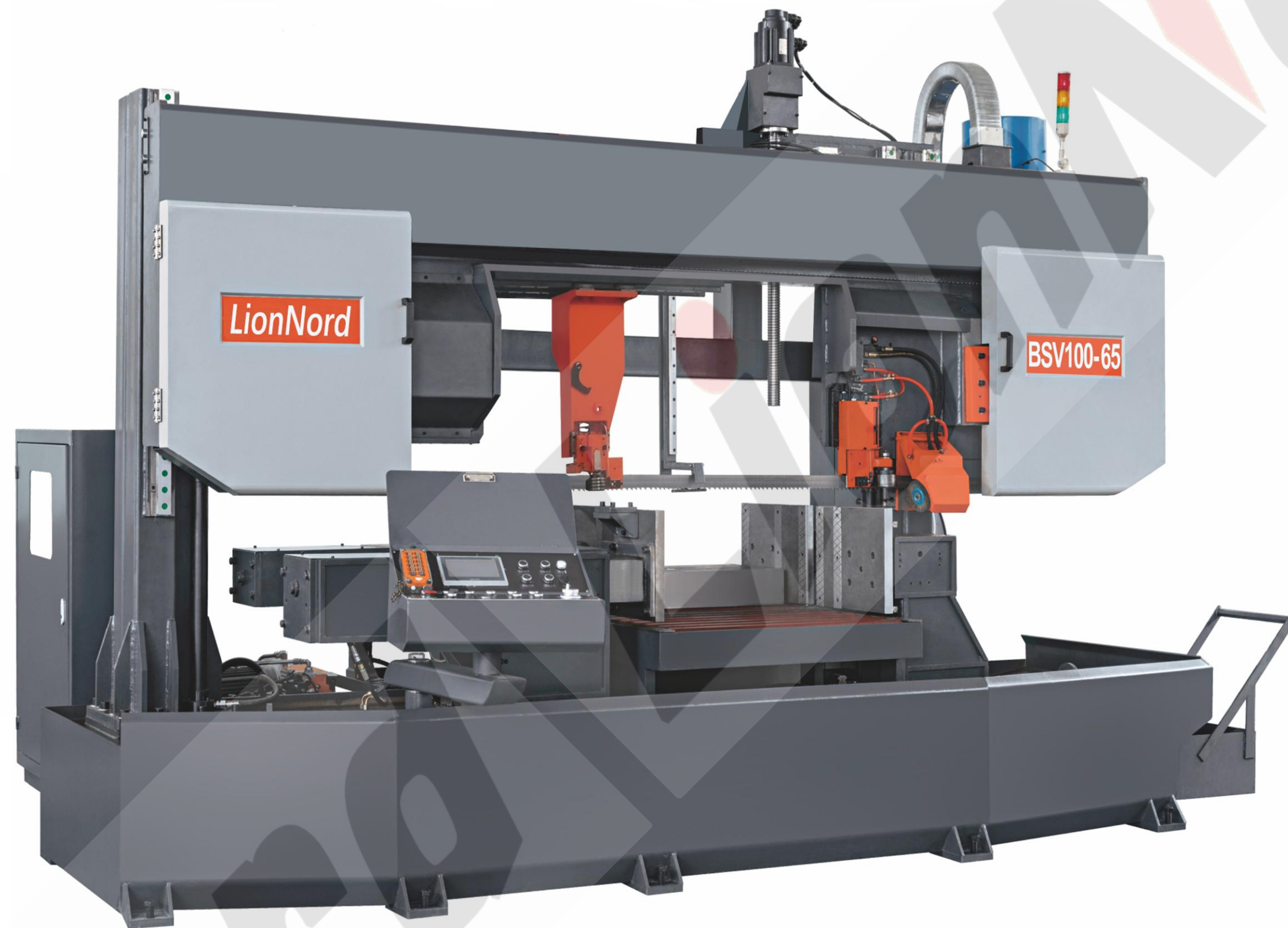
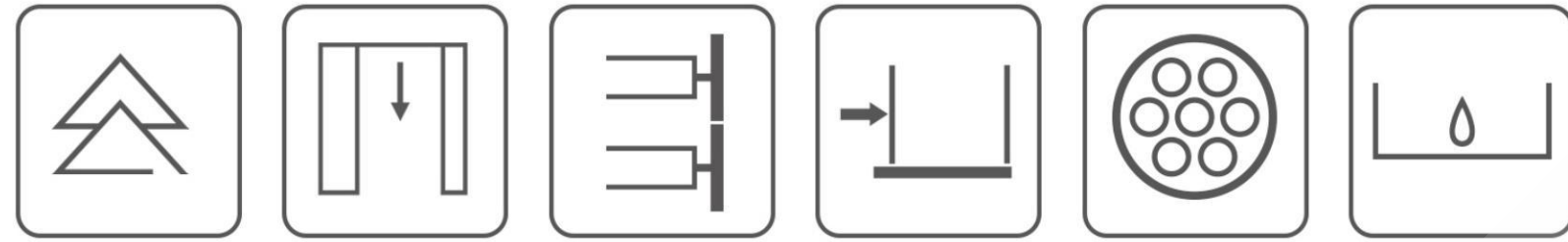

CUTTING CAPACITY MM	BLADE SIZE MM	BLADE SPEED M/MIN	MAIN MOTOR KW	COOLING MOTOR W	HYDRAULIC MOTOR KW	MACHINE SIZE (L*W*H) MM	WEIGHT KG
1000*650	54*1.6mm	15-70	15 (6P)	1000	2.25	4500X2800X2950	8000

CUTTING CAPACITY MM	BLADE SIZE MM	BLADE SPEED M/MIN	MAIN MOTOR KW	COOLING MOTOR W	HYDRAULIC MOTOR KW	MACHINE SIZE (L*W*H) MM	WEIGHT KG
1200*850	1.6*67	15-70	18.5	1000	2.25	5200*2850*3500	12000

ABS-330B

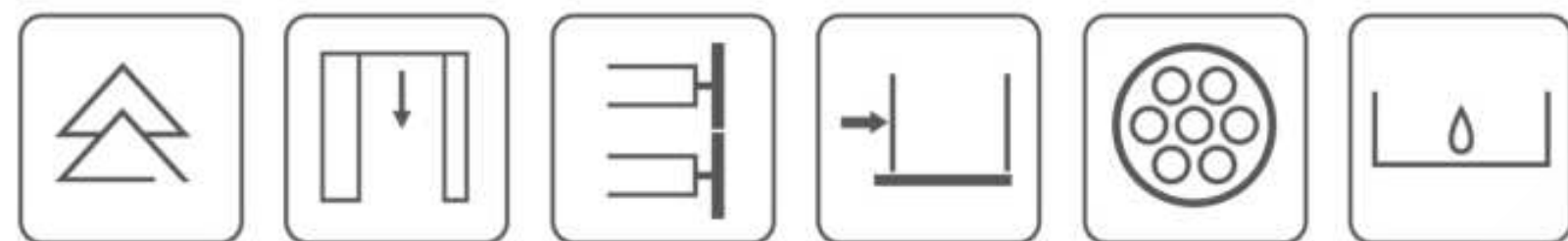

CUTTING CAPACITY MM	BLADE SIZE MM	BLADE SPEED M/MIN	MAIN MOTOR KW	COOLING MOTOR W	HYDRAULIC MOTOR KW	MACHINE SIZE (L*W*H) MM	WEIGHT KG
330X330	34X1.1X4115	20/40/50/75	4	40	0.75	2150X1950X1700	1400

ABS-330C

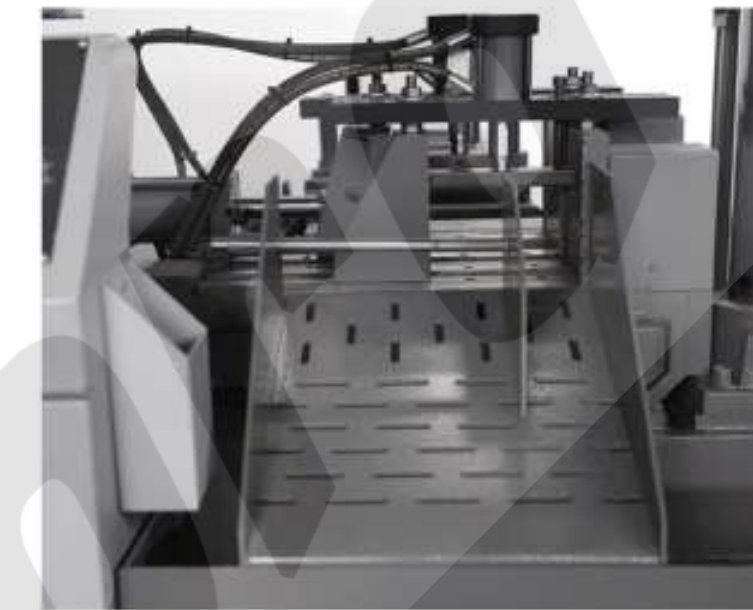
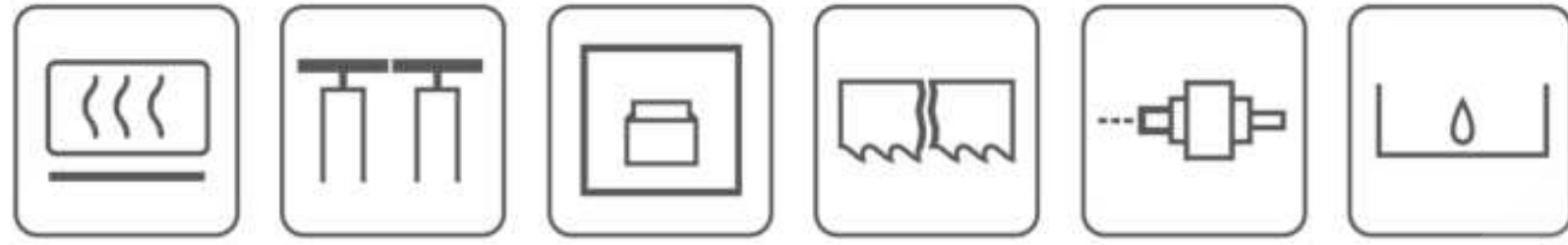

CUTTING CAPACITY	330X330MM	TABLE HEIGHT	500MM
BLADE SIZE	34X1.1X4115MM	WISE CLAMP HEIGHT	180MM
BLADE SPEED	26/40/61/84M/MIN	WEIGHT	1577KG
MAIN MOTOR	4KW 4级	MACHINE SIZE	2150X2230X1380MM
COOLING MOTOR	0.09KW	MACHINE SIZE (SAW FRAME RAISED)	2150X2230X1620MM
HYDRAULIC MOTOR	0.75KW	ROLLER TABLE SIZE (L*W*H)	600X470X605MM

IBS-33NC

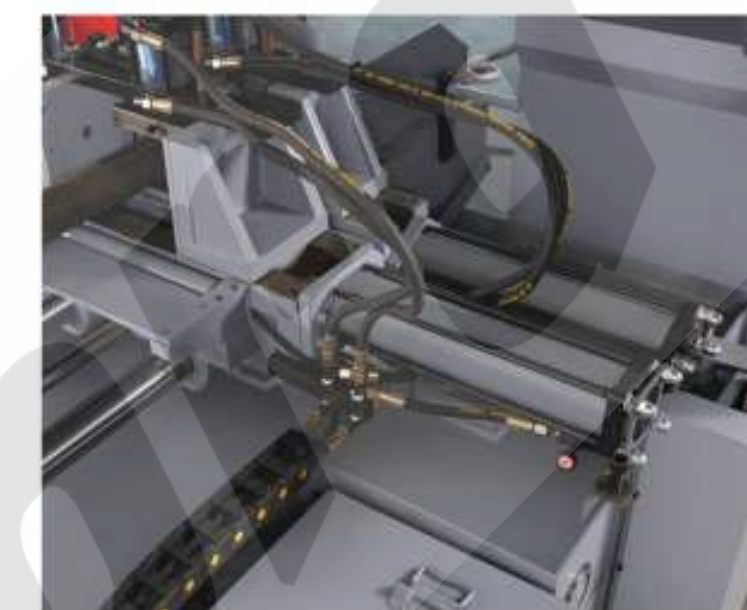

CUTTING CAPACITY	330X330MM	TABLE HEIGHT	500MM
BLADE SIZE	34X1.1X4115MM	WISE CLAMP HEIGHT	180MM
BLADE SPEED	20~80(变频)M/MIN	WEIGHT	
MAIN MOTOR	4KW 4级	MACHINE SIZE	1800KG
COOLING MOTOR	0.09KW	MACHINE SIZE (SAW FRAME RAISED)	2300X2200X1450MM
HYDRAULIC MOTOR	0.75KW	ROLLER TABLE SIZE (L*W*H)	2300X2200X1700MM

ABS-400

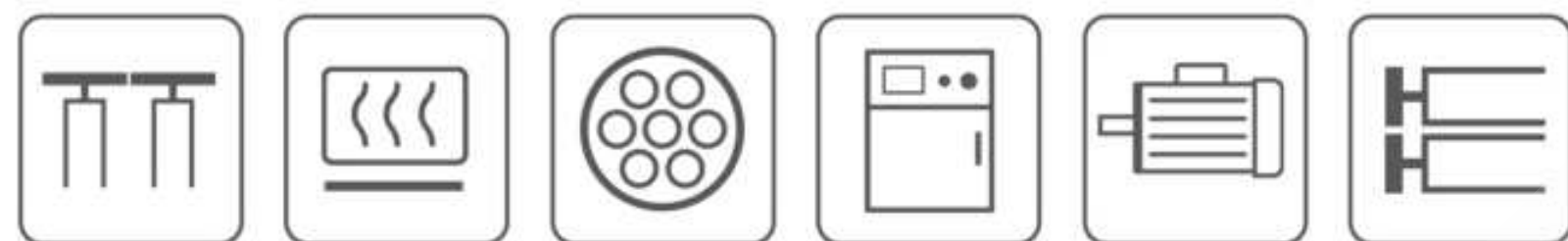

CUTTING CAPACITY MM	BLADE SIZE MM	BLADE SPEED M/MIN	MAIN MOTOR KW	COOLING MOTOR W	HYDRAULIC MOTOR KW	MACHINE SIZE (L*W*H) MM	WEIGHT KG
400X400	41X1.3X4700	17/27/44/57/65	4	40	0.75	2500X2100X1650	1970

ABS-500

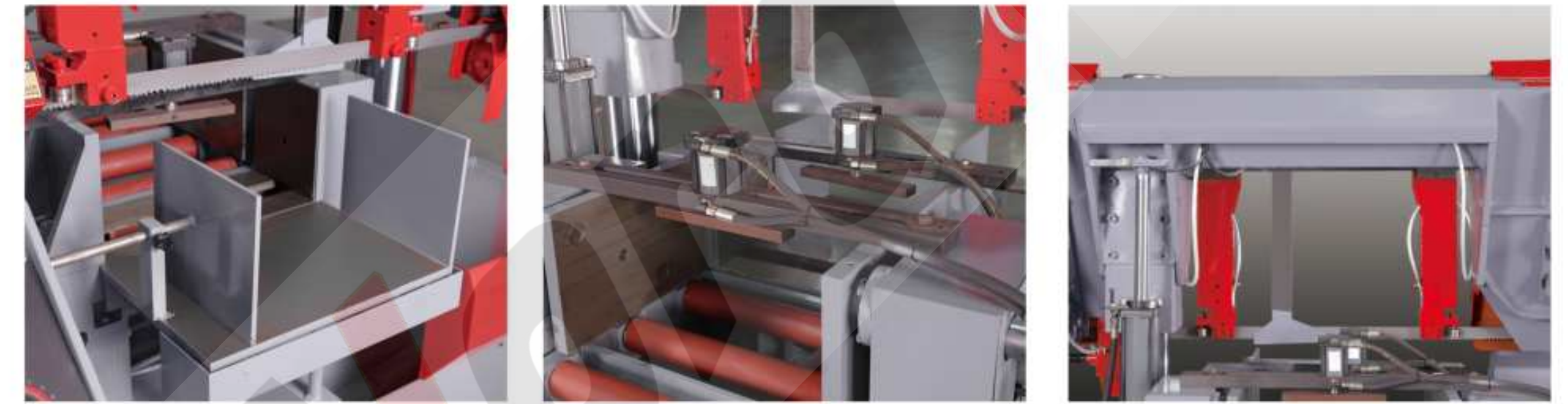
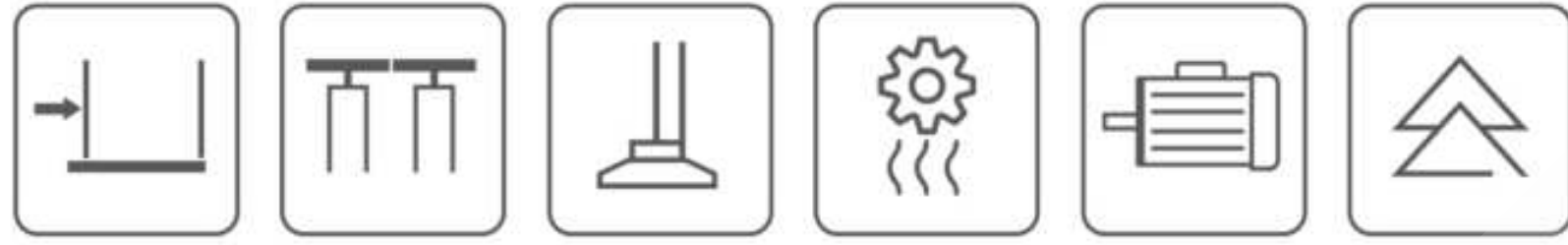

CUTTING CAPACITY MM	BLADE SIZE MM	BLADE SPEED M/MIN	MAIN MOTOR KW	COOLING MOTOR W	HYDRAULIC MOTOR KW	MACHINE SIZE (L*W*H) MM	WEIGHT KG
500X500	41X1.3X5540	23/44/71	5.5(6P)	90	1.5	2700X2200X1900	2850

ABS-650

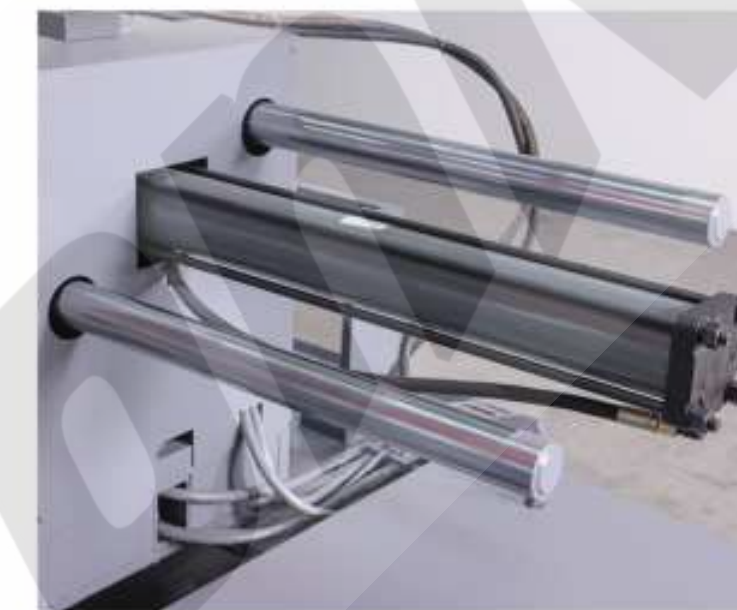

CUTTING CAPACITY MM	BLADE SIZE MM	BLADE SPEED M/MIN	MAIN MOTOR KW	COOLING MOTOR W	HYDRAULIC MOTOR KW	MACHINE SIZE (L*W*H) MM	WEIGHT KG
650X650	54X1.6X6530	18-60(变频)	7.5	90	1.5	3100X3000X2400	5250

RBS-280

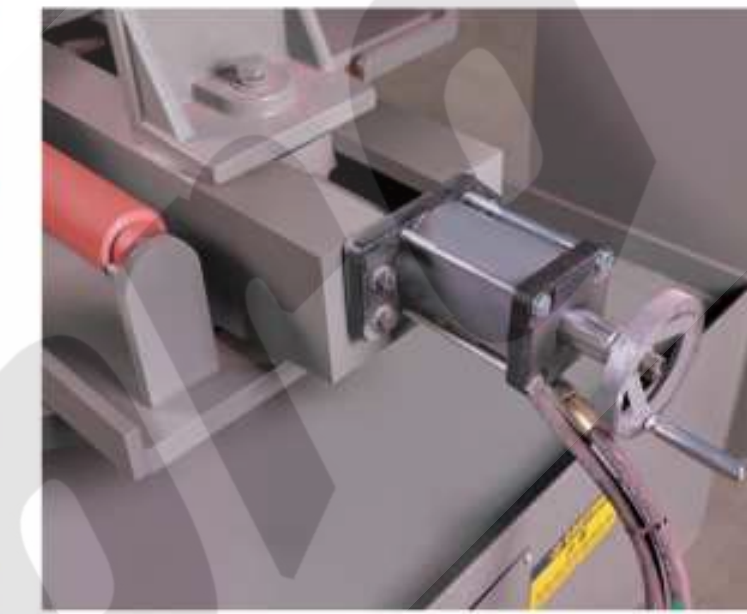
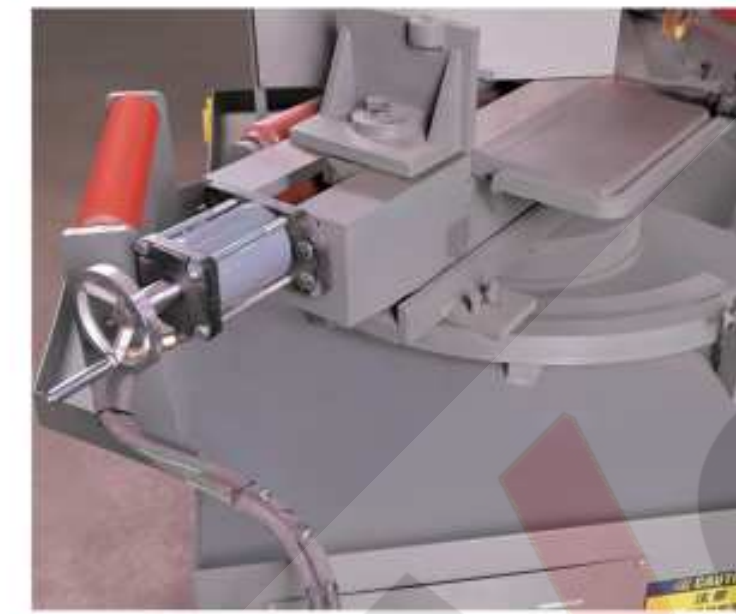
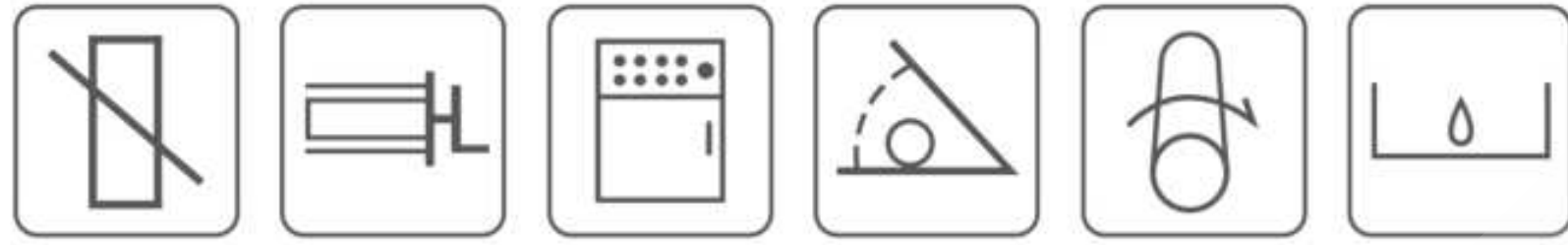

CUTTING CAPACITY MM	BLADE SIZE MM	BLADE SPEED M/MIN	MAIN MOTOR KW	COOLING MOTOR W	HYDRAULIC MOTOR KW	MACHINE SIZE (L*W*H) MM	WEIGHT KG
0°: O280 □280X440 45°: O280 □230X270	34X1.1X3860	26/48/70	3	40	0.75	2070X1470X1370	1100

RBS-330D

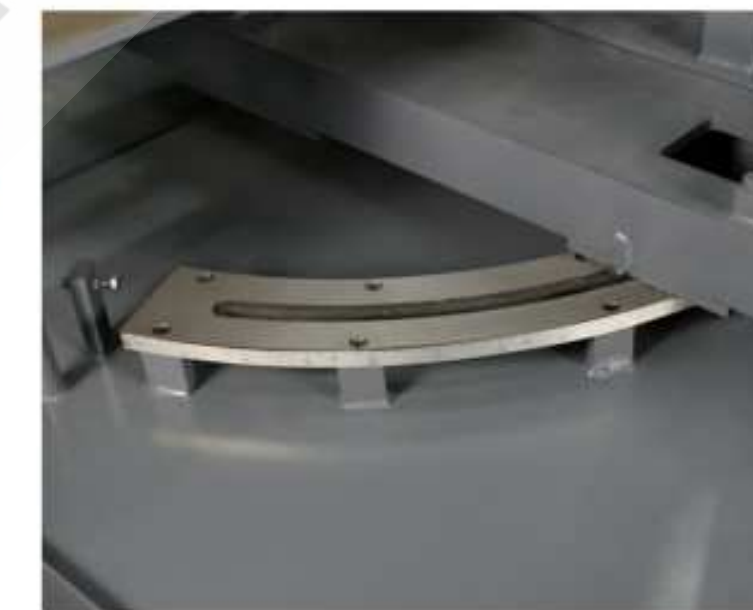
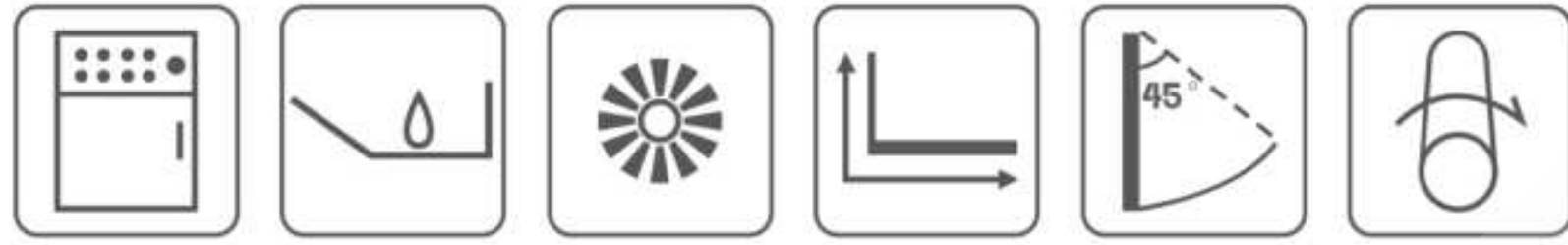

CUTTING CAPACITY MM	BLADE SIZE MM	BLADE SPEED M/MIN	MAIN MOTOR KW	COOLING MOTOR W	HYDRAULIC MOTOR KW	MACHINE SIZE (L*W*H) MM	WEIGHT KG
0°: 330X500	34X1.1X4630	33/47/58/86	4	40	0.75	2450X1950X1650	1650
45°: 330X380							
H型钢0°-45°: 330X350							

GZ4233X

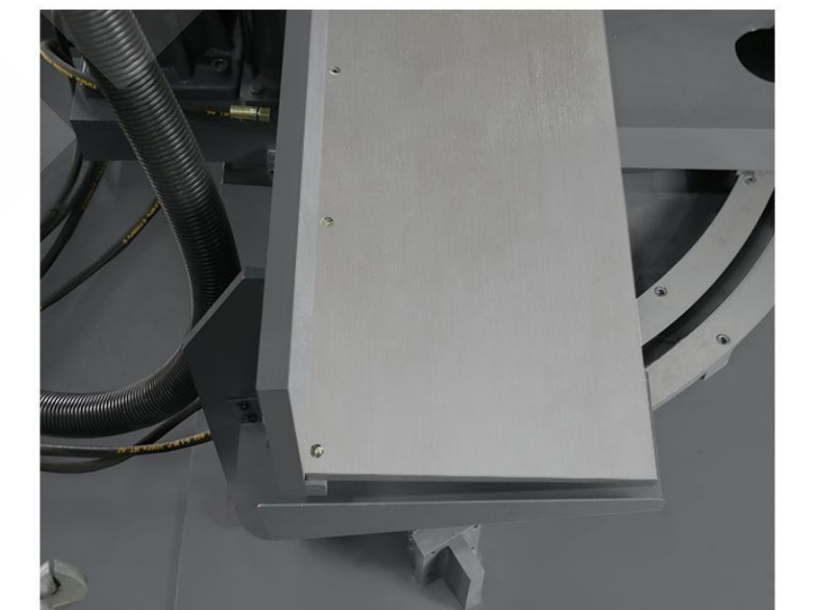
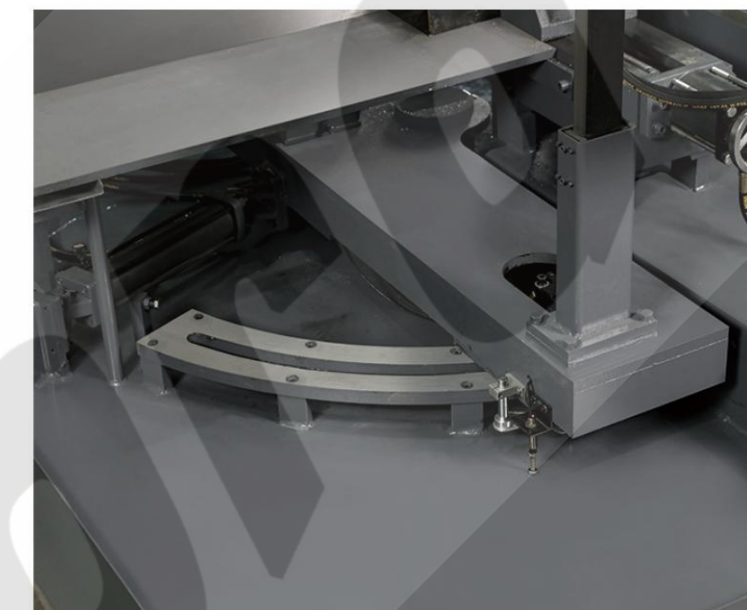
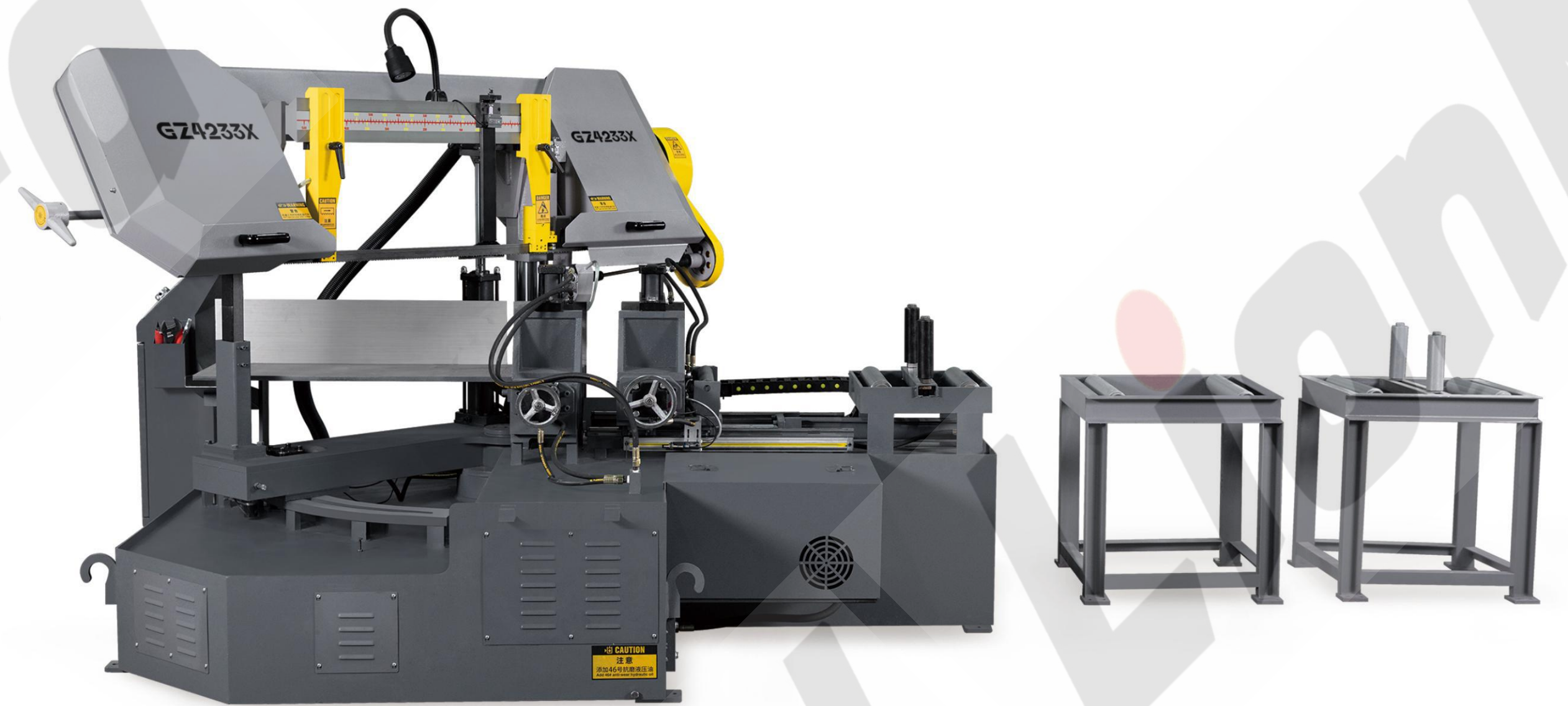
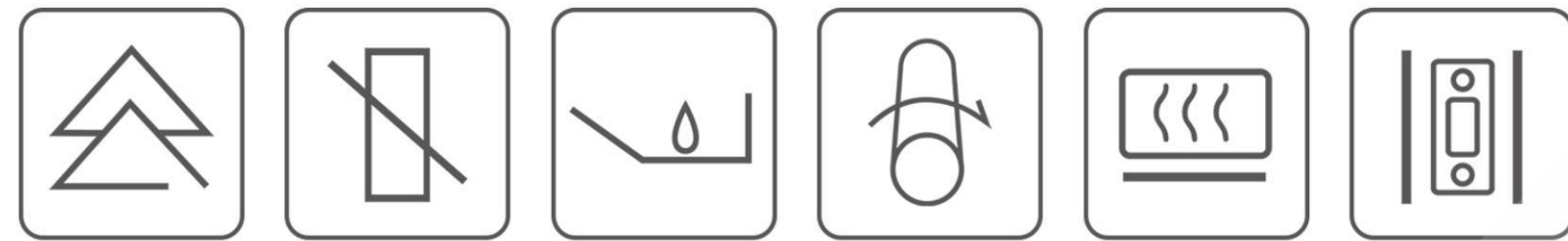

CUTTING CAPACITY MM	BLADE SIZE MM	BLADE SPEED M/MIN	MAIN MOTOR KW	COOLING MOTOR W	HYDRAULIC MOTOR KW	MACHINE SIZE (L*W*H) MM	WEIGHT KG
0°:330X330 45°:330X330	34X1.1X4630	32/48/60/86	4	40	0.75	2740X2440X1700	1930

RBS-350

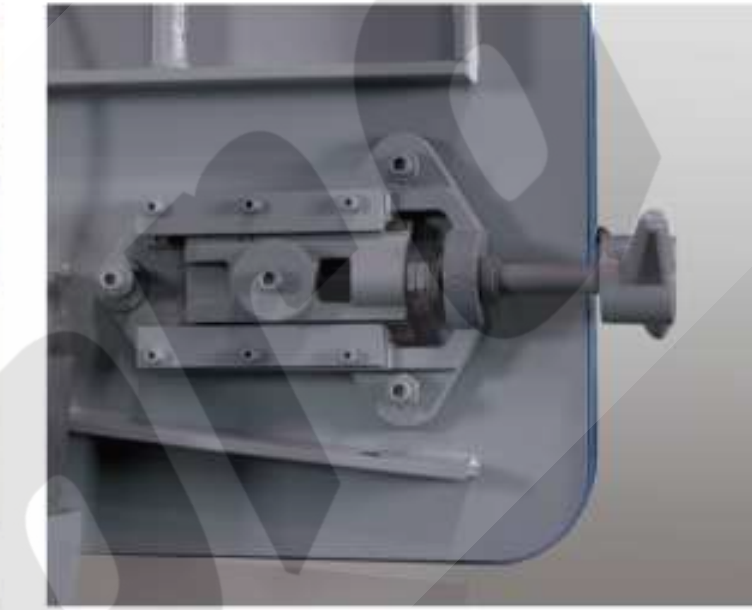
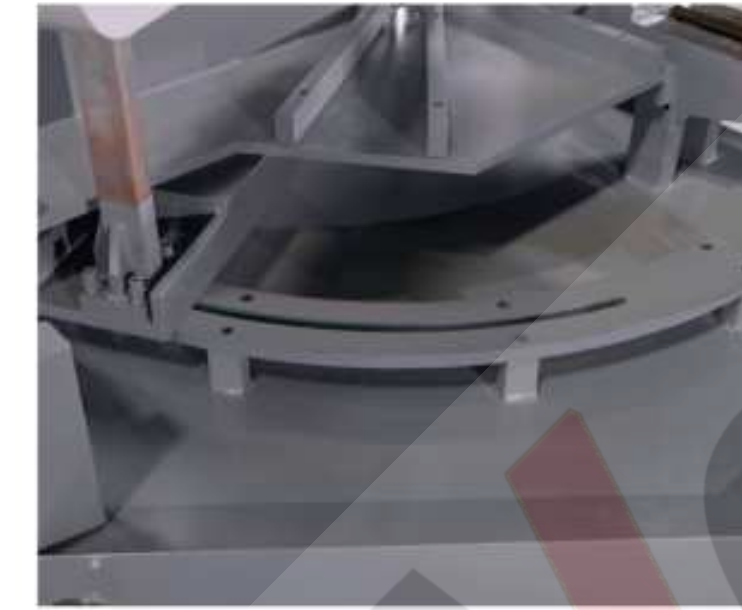
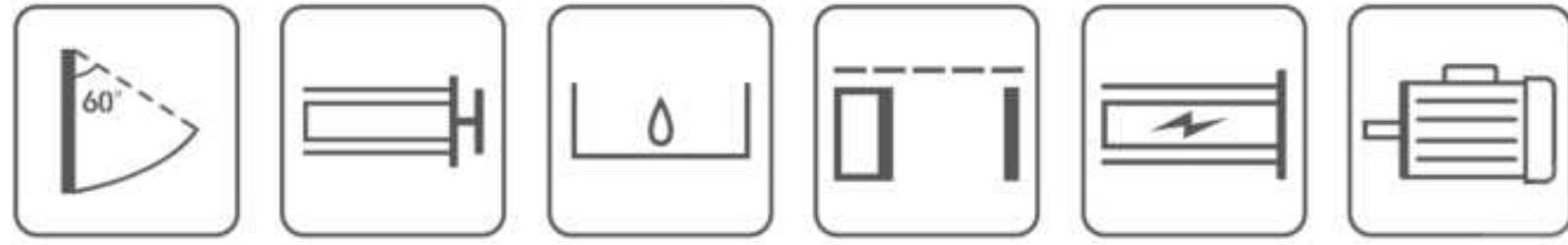

CUTTING CAPACITY MM	BLADE SIZE MM	BLADE SPEED M/MIN	MAIN MOTOR KW	COOLING MOTOR W	HYDRAULIC MOTOR KW	MACHINE SIZE (L*W*H) MM	WEIGHT KG
0°: 350X500	34X1.1X4980	23/43/62/75	4	60	0.75	2600X2000X1850	2100
45°: 350X390							
60°: 350X200							

RBS-450

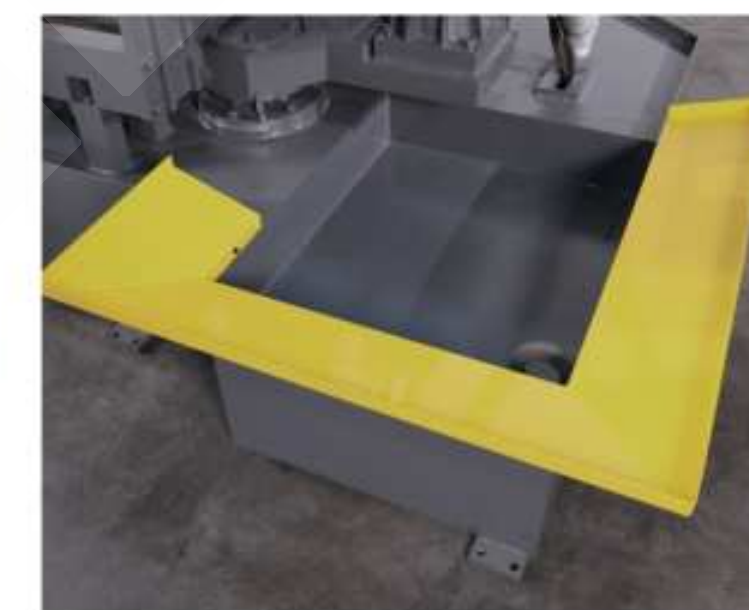
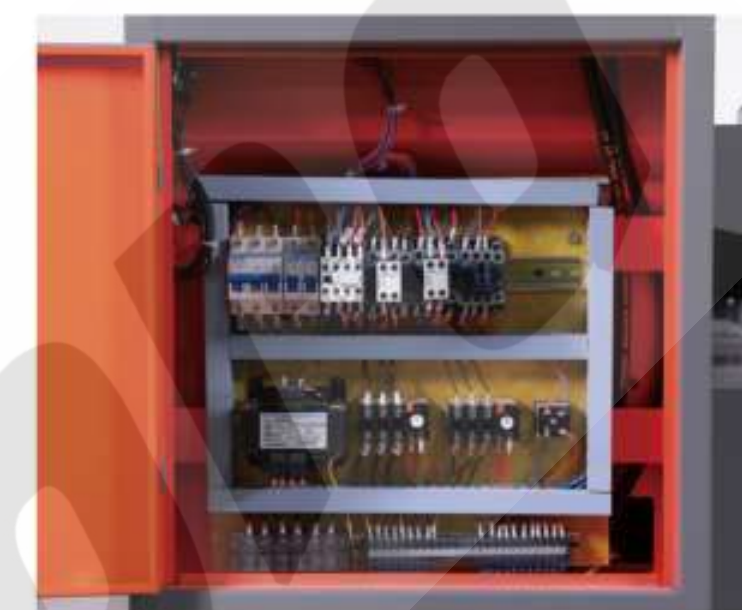

CUTTING CAPACITY MM	BLADE SIZE MM	BLADE SPEED M/MIN	MAIN MOTOR KW	COOLING MOTOR W	HYDRAULIC MOTOR KW	MACHINE SIZE (L*W*H) MM	WEIGHT KG
0°: 450X500 45°: 450X480 60°: 350X350	41X1.3X5850	23/43/62/70	4	90	0.75	2860X1970X2030	2240

BBS-350

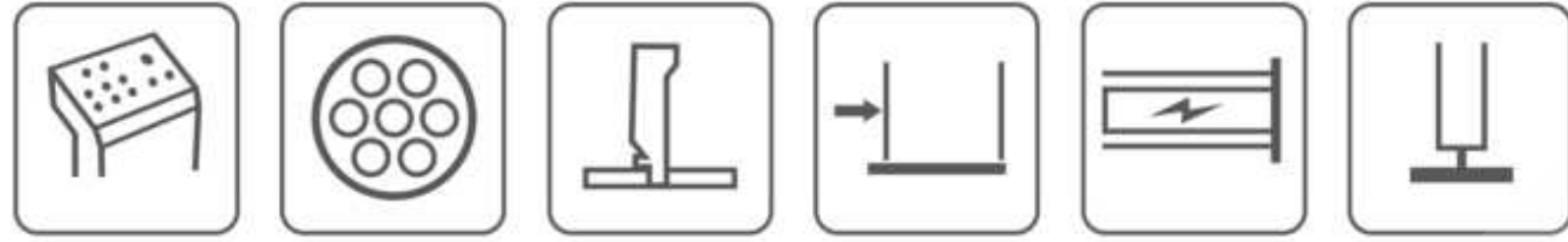

CUTTING CAPACITY MM	BLADE SIZE MM	BLADE SPEED M/MIN	MAIN MOTOR KW	COOLING MOTOR W	HYDRAULIC MOTOR KW	MACHINE SIZE (L*W*H) MM	WEIGHT KG
350X450	34X1.1X4670	30/44/56/74	4	40	0.75	2500X1060X1650	1190

BBS-450

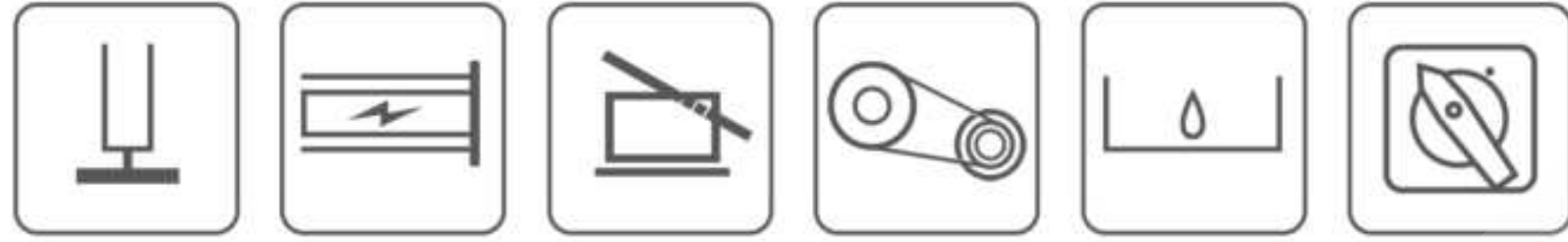

CUTTING CAPACITY MM	BLADE SIZE MM	BLADE SPEED M/MIN	MAIN MOTOR KW	COOLING MOTOR W	HYDRAULIC MOTOR KW	MACHINE SIZE (L*W*H) MM	WEIGHT KG
450X500	41X1.3X5340	15/25/42/55/63	4	90	0.75	2650X1120X1835	1488

BBS-500

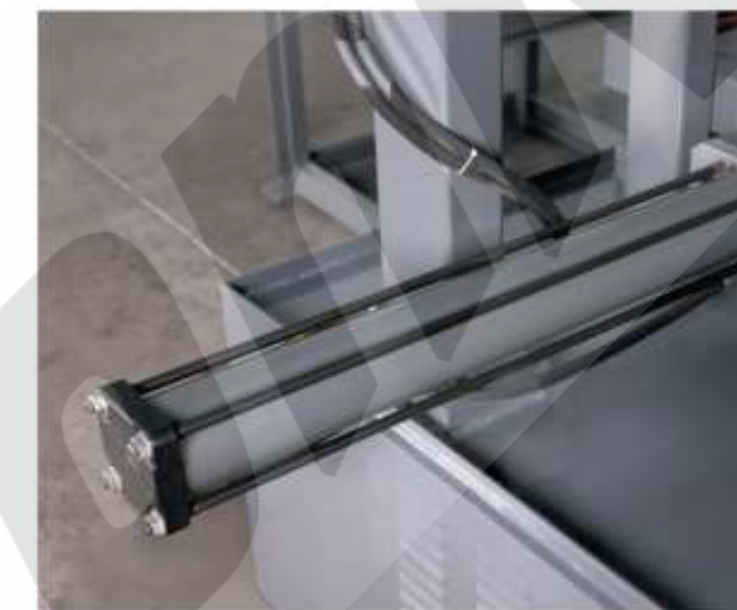
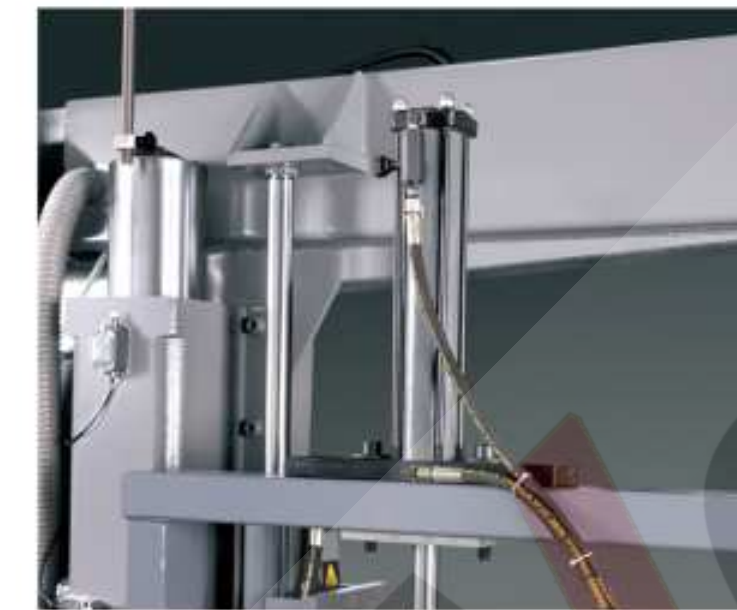

CUTTING CAPACITY MM	BLADE SIZE MM	BLADE SPEED M/MIN	MAIN MOTOR KW	COOLING MOTOR W	HYDRAULIC MOTOR KW	MACHINE SIZE (L*W*H) MM	WEIGHT KG
500X600	41X1.3X5640	23/44/71	4	90	0.75	2930X1340X2130	2050

H-7040S

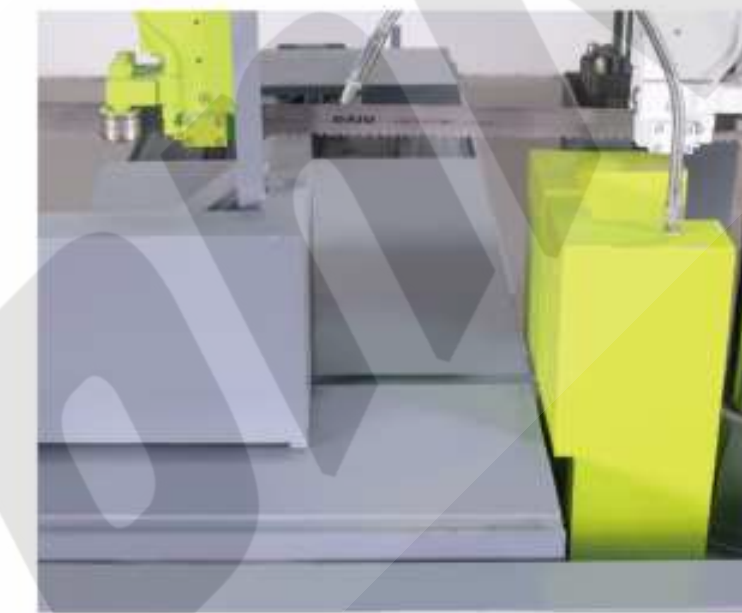
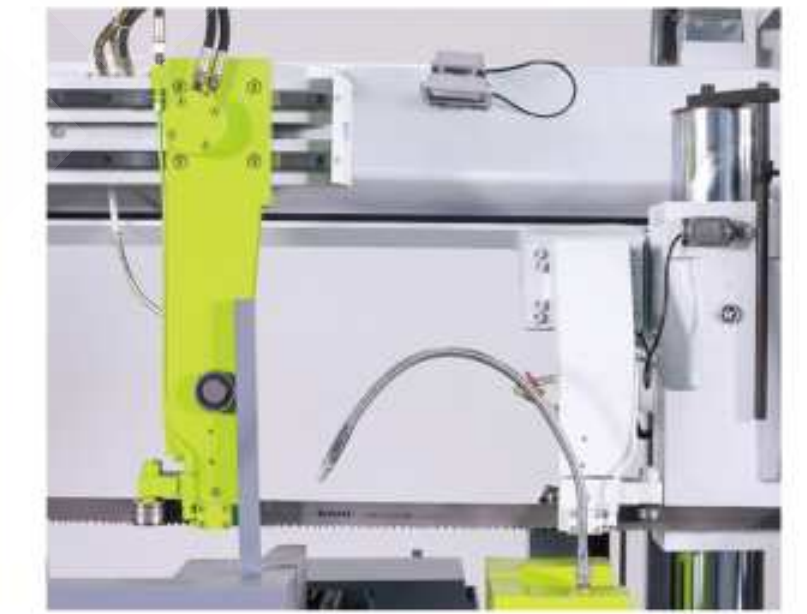
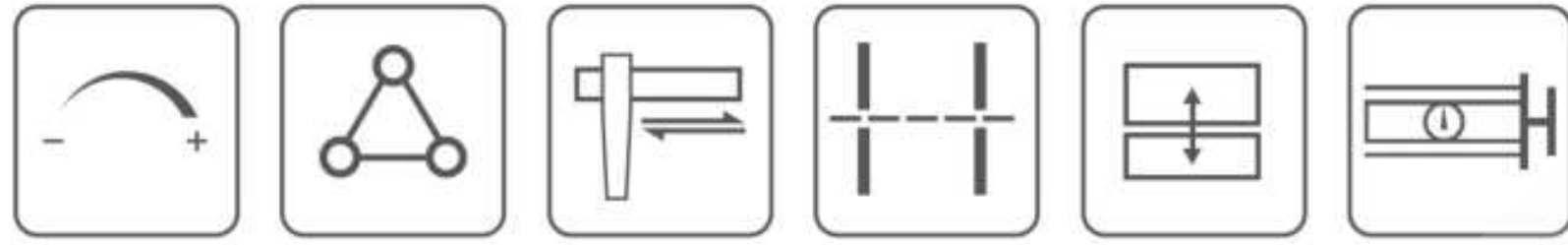

CUTTING CAPACITY MM	BLADE SIZE MM	BLADE SPEED M/MIN	MAIN MOTOR KW	COOLING MOTOR W	HYDRAULIC MOTOR KW	MACHINE SIZE (L*W*H) MM	WEIGHT KG
700X400	41X1.3X5720	10-60(变频)	7.5	90	1.5	2900X1500X1750	3290

H-9050S

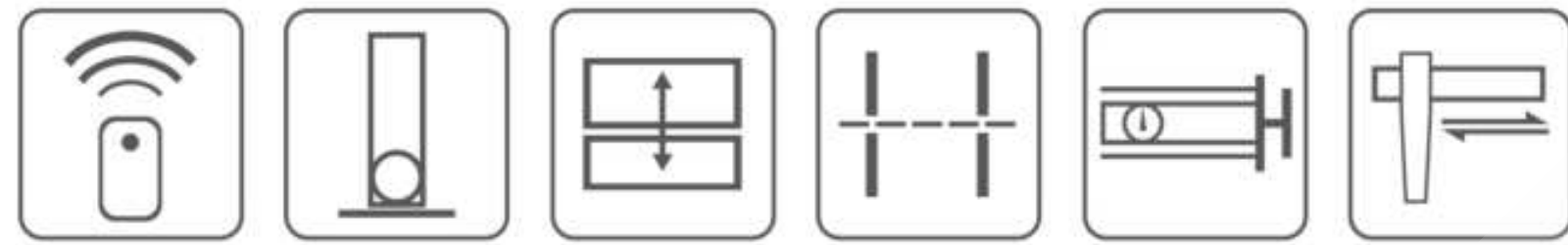

CUTTING CAPACITY MM	BLADE SIZE MM	BLADE SPEED M/MIN	MAIN MOTOR KW	COOLING MOTOR W	HYDRAULIC MOTOR KW	MACHINE SIZE (L*W*H) MM	WEIGHT KG
900X500	54X1.6X6830	20-69(变频)	7.5	120	1.5	4100X2200X2100	6100

P280

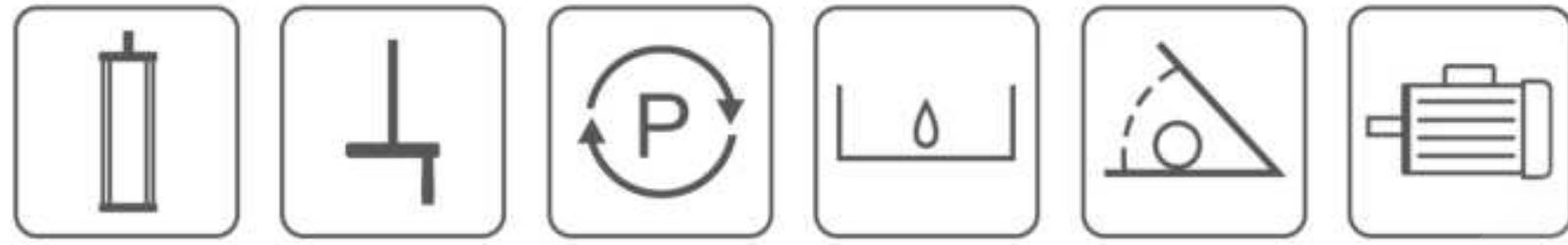

CUTTING CAPACITY MM	BLADE SIZE MM	BLADE SPEED M/MIN	MAIN MOTOR KW	COOLING MOTOR W	HYDRAULIC MOTOR KW	MACHINE SIZE (L*W*H) MM	WEIGHT KG
○280 □250X390	27X0.9X3505	26/49/68	2.2	40	0.75	1860X1200X1800	800

P380

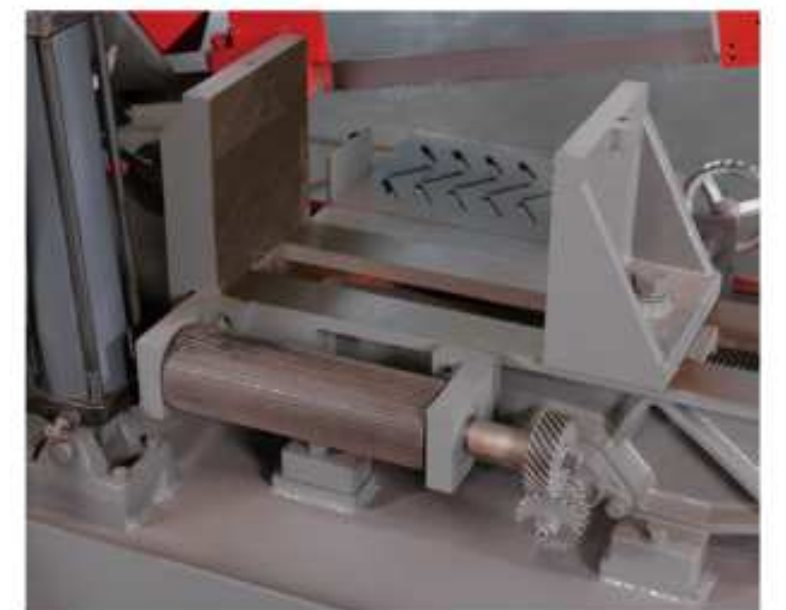
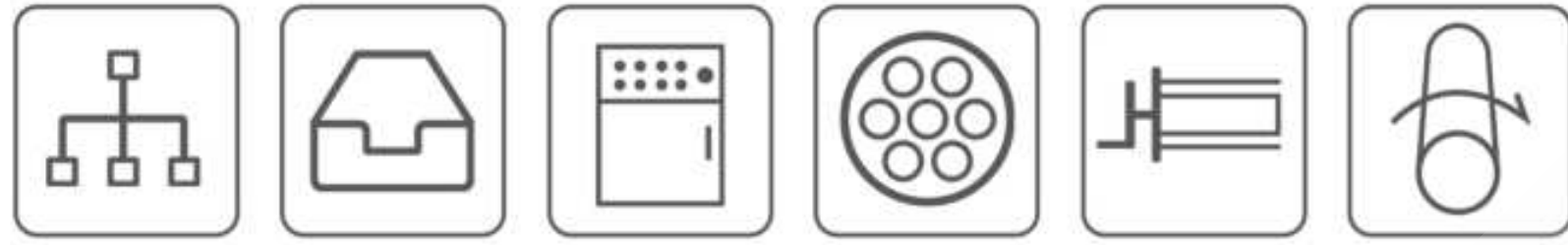

CUTTING CAPACITY MM	BLADE SIZE MM	BLADE SPEED M/MIN	MAIN MOTOR KW	COOLING MOTOR W	HYDRAULIC MOTOR KW	MACHINE SIZE (L*W*H) MM	WEIGHT KG
○380 □330X430	34X1.1X4115	28/50/70	3	90	0.75	2120X1200X1310	880

MT-300

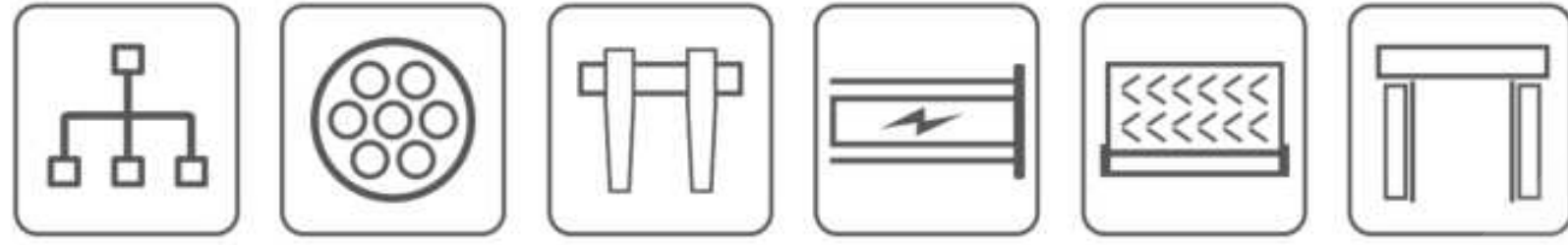

CUTTING CAPACITY MM	BLADE SIZE MM	BLADE SPEED M/MIN	MAIN MOTOR KW	COOLING MOTOR W	HYDRAULIC MOTOR KW	MACHINE SIZE (L*W*H) MM	WEIGHT KG
300X380	27X0.9X3505	25/49/74	3	40	0.75	1900X1100X1600	770

MT-330

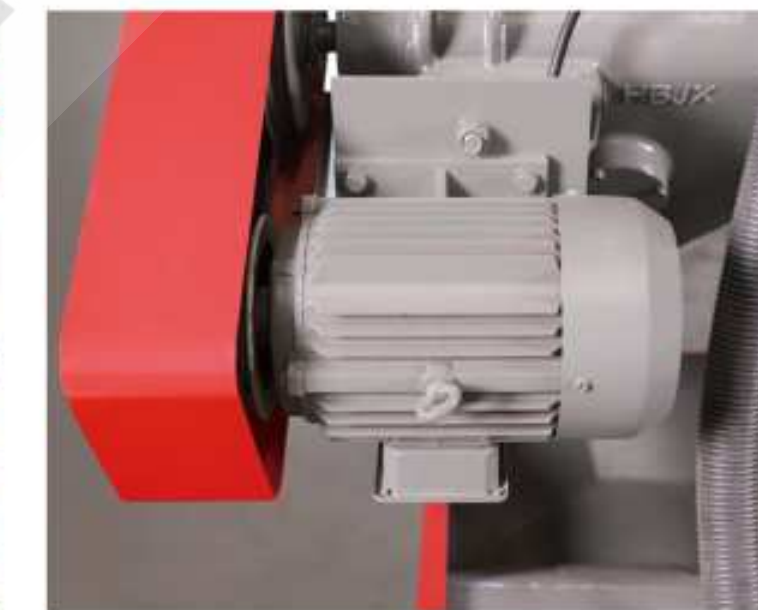
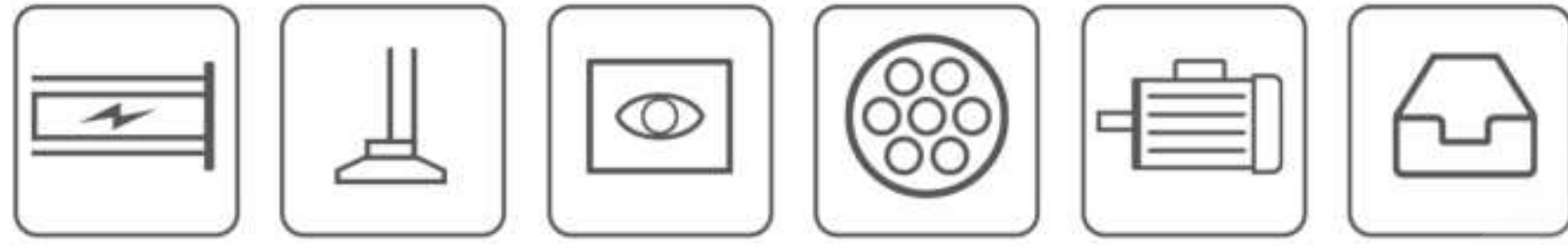

CUTTING CAPACITY MM	BLADE SIZE MM	BLADE SPEED M/MIN	MAIN MOTOR KW	COOLING MOTOR W	HYDRAULIC MOTOR KW	MACHINE SIZE (L*W*H) MM	WEIGHT KG
330X450	34X1.1X4115	21/36/46/68	3	40	0.75	2000X1200X1600	960

MT-350

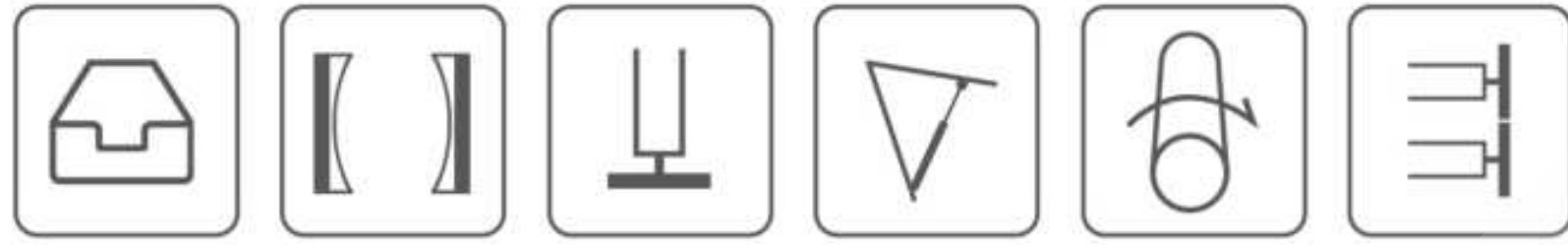

CUTTING CAPACITY MM	BLADE SIZE MM	BLADE SPEED M/MIN	MAIN MOTOR KW	COOLING MOTOR W	HYDRAULIC MOTOR KW	MACHINE SIZE (L*W*H) MM	WEIGHT KG
350X420	34X1.1X4115	21/36/46/68	3	40	0.75	2300X1200X1650	1030

MT-400



CUTTING CAPACITY MM	BLADE SIZE MM	BLADE SPEED M/MIN	MAIN MOTOR KW	COOLING MOTOR W	HYDRAULIC MOTOR KW	MACHINE SIZE (L*W*H) MM	WEIGHT KG
400X500	41X1.3X4760	32/46/58/79	4	90	0.75	2560X1130X1650	1225

MT-70/40

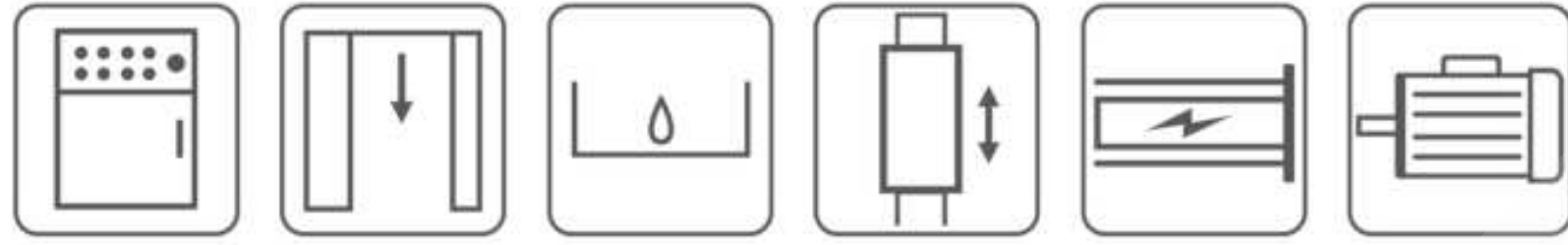

CUTTING CAPACITY MM	BLADE SIZE MM	BLADE SPEED M/MIN	MAIN MOTOR KW	COOLING MOTOR W	HYDRAULIC MOTOR KW	MACHINE SIZE (L*W*H) MM	WEIGHT KG
400X700	41X1.3X5100	17/27/50/58/74	4	90	0.75	2800X1100X1650	1360

MT-65/50S

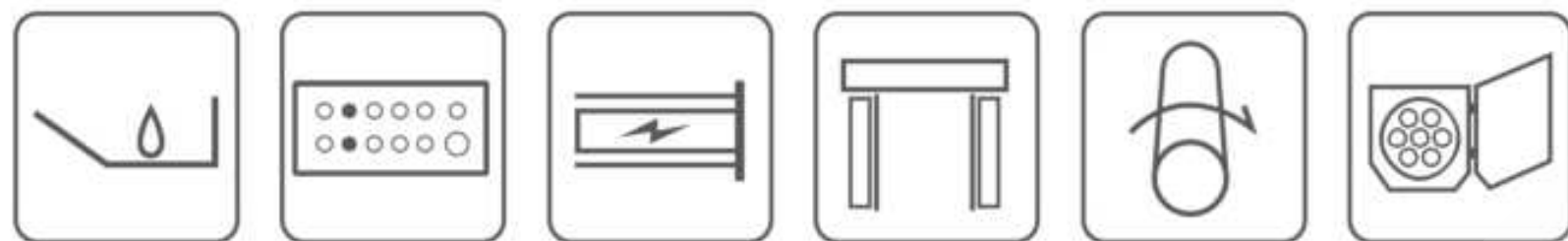

CUTTING CAPACITY	500X650MM	TABLE HEIGHT	640MM
BLADE SIZE	41X1.3X5335MM	WISE CLAMP HEIGHT	260MM
BLADE SPEED	23/45/72M/MIN	WEIGHT	1900KG
MAIN MOTOR	5.5KW 6级	MACHINE SIZE	2750X1200X2100MM
COOLING MOTOR	0.09KW	MACHINE SIZE (SAW FRAME RAISED)	2750X1200X2100MM
HYDRAULIC MOTOR	1.5KW	ROLLER TABLE SIZE (L*W*H)	790X610X630MM

MT-70/50

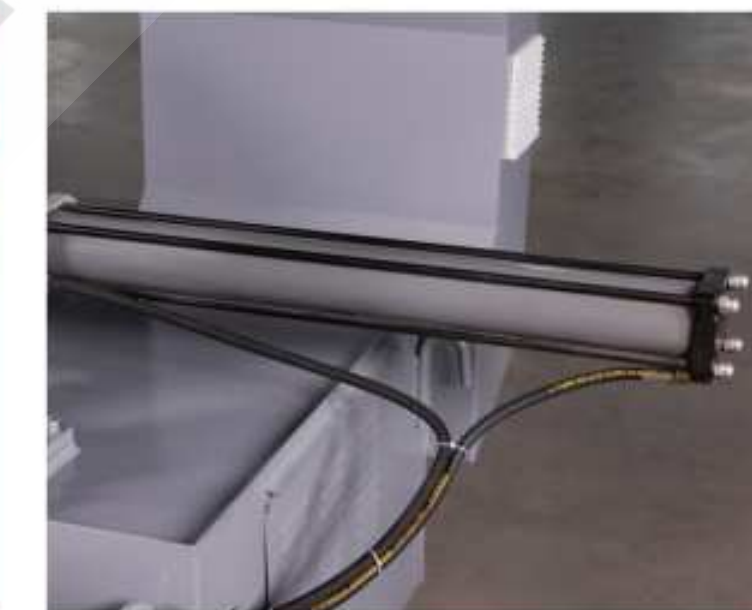
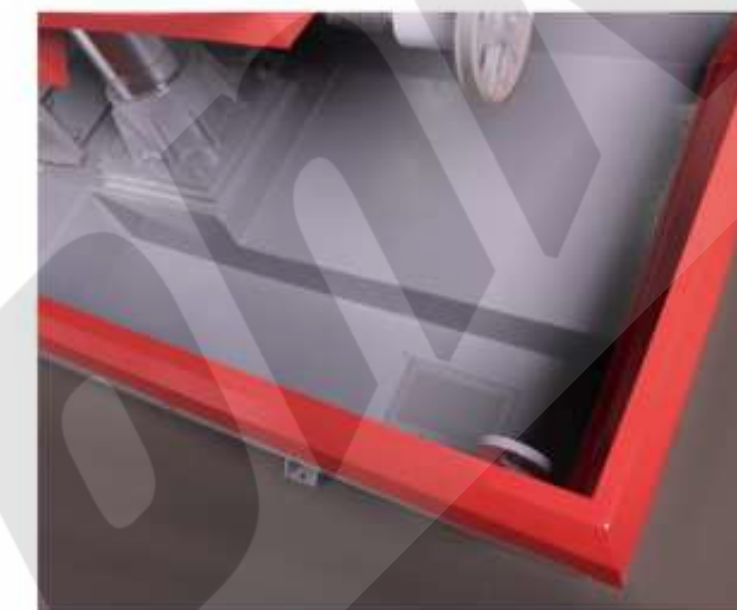
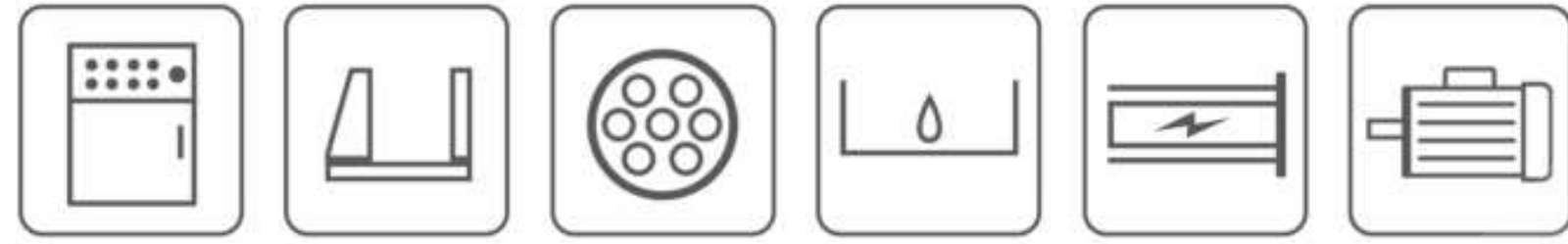

CUTTING CAPACITY MM	BLADE SIZE MM	BLADE SPEED M/MIN	MAIN MOTOR KW	COOLING MOTOR W	HYDRAULIC MOTOR KW	MACHINE SIZE (L*W*H) MM	WEIGHT KG
500X700	41X1.3X5740	23/44/71	4	90	1.5	3000X1350X1950	1820

MT-70/50S

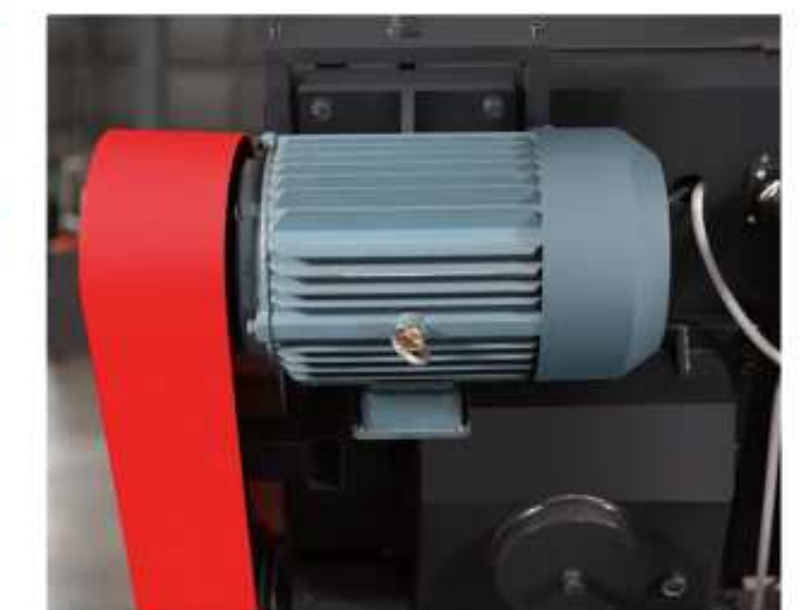
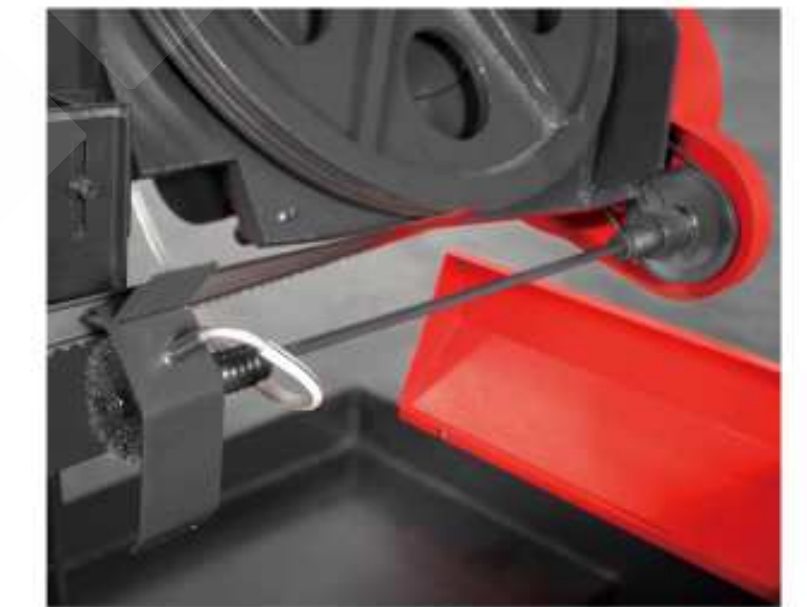
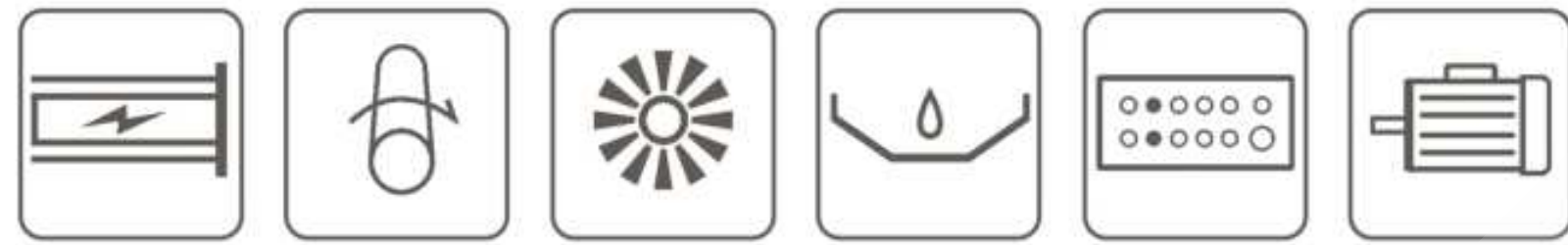

CUTTING CAPACITY	500X700MM	TABLE HEIGHT	700MM
BLADE SIZE	41X1.3X5740MM	WISE CLAMP HEIGHT	260MM
BLADE SPEED	23/46/71M/MIN	WEIGHT	1880KG
MAIN MOTOR	5.5KW 6级	MACHINE SIZE	2965X1250X1900MM
COOLING MOTOR	0.09KW	MACHINE SIZE (SAW FRAME RAISED)	2965X1250X2150MM
HYDRAULIC MOTOR	1.5KW	ROLLER TABLE SIZE (L*W*H)	808X790X690MM

MT-80/65

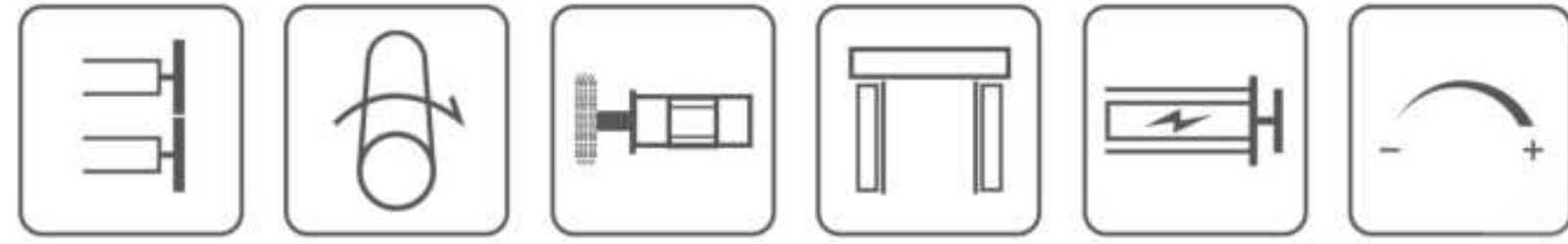

CUTTING CAPACITY	650X800MM	SINGLE FEEDING LENGTH	2000MM
BLADE SIZE	54X1.6X6900MM	MINIMUM CLAMPING DISTANCE	350MM
BLADE SPEED	10-60(变频)M/MIN	DISTANCE BETWEEN FRONT AND REAR JAWS	355MM
MAIN MOTOR	7.5KW 6级	WEIGHT	3900KG
COOLING MOTOR	0.09KW	MACHINE SIZE	3180X1700X2350MM
HYDRAULIC MOTOR	1.5KW	ROLLER TABLE SIZE (L*W*H)	2000X809X465MM

MT-90/70

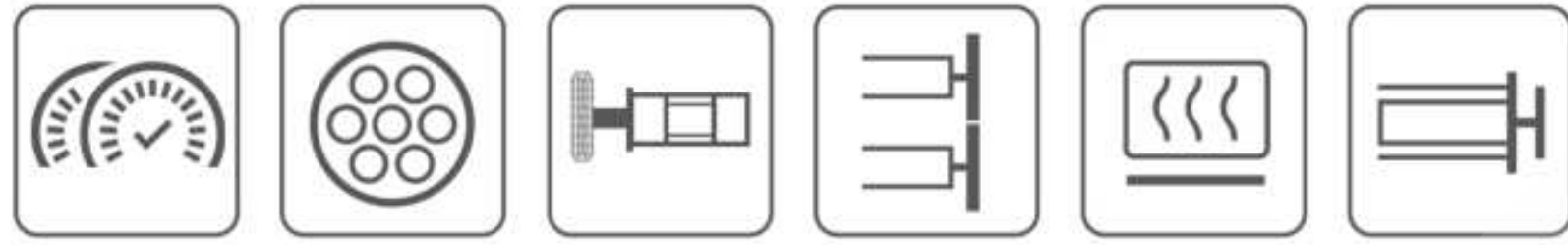

CUTTING CAPACITY	700X900MM	SINGLE FEEDING LENGTH	2000MM
BLADE SIZE	54X1.6X7970MM	MINIMUM CLAMPING DISTANCE	350MM
BLADE SPEED	10-63(变频)M/MIN	DISTANCE BETWEEN FRONT AND REAR JAWS	400、150MM
MAIN MOTOR	1.1KW	WEIGHT	5505KG
COOLING MOTOR	0.12KW	MACHINE SIZE	3750X1970X2270MM
HYDRAULIC MOTOR	2.2KW	ROLLER TABLE SIZE (L*W*H)	1800X920MM

MT-1000

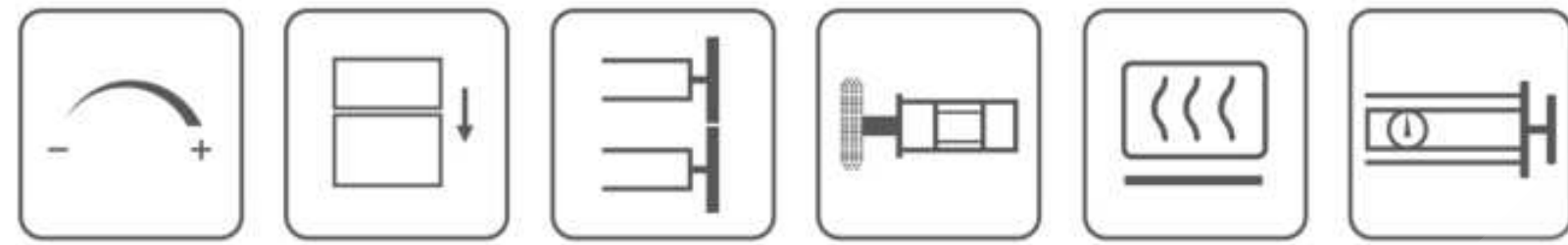

CUTTING CAPACITY	1000X1000MM	SINGLE FEEDING LENGTH	1500MM
BLADE SIZE	67X1.6X10100MM	MINIMUM CLAMPING DISTANCE	450MM
BLADE SPEED	10-80(变频)M/MIN	DISTANCE BETWEEN FRONT AND REAR JAWS	350MM
MAIN MOTOR	11KW 6级	WEIGHT	9790KG
COOLING MOTOR	0.12KW	MACHINE SIZE	4600X1960X2900MM
HYDRAULIC MOTOR	2.2KW	ROLLER TABLE SIZE (L*W*H)	大2700X900 / 小550X900MM

MT-140/120

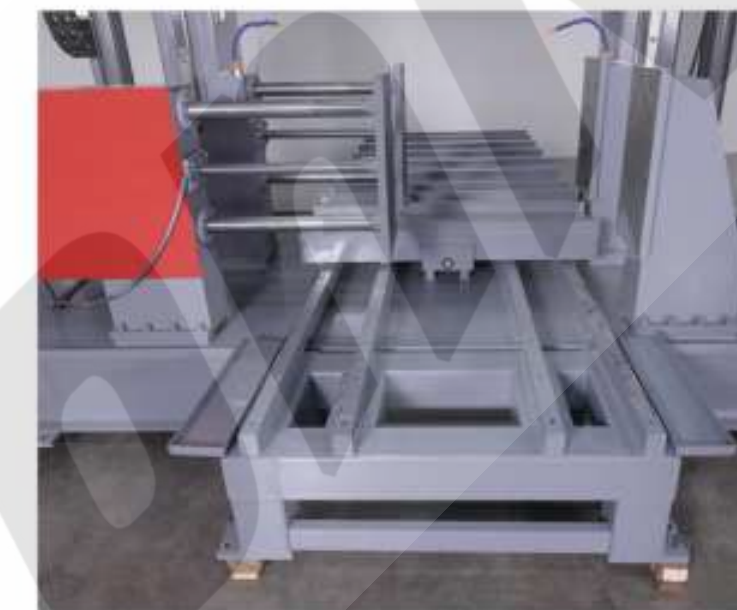
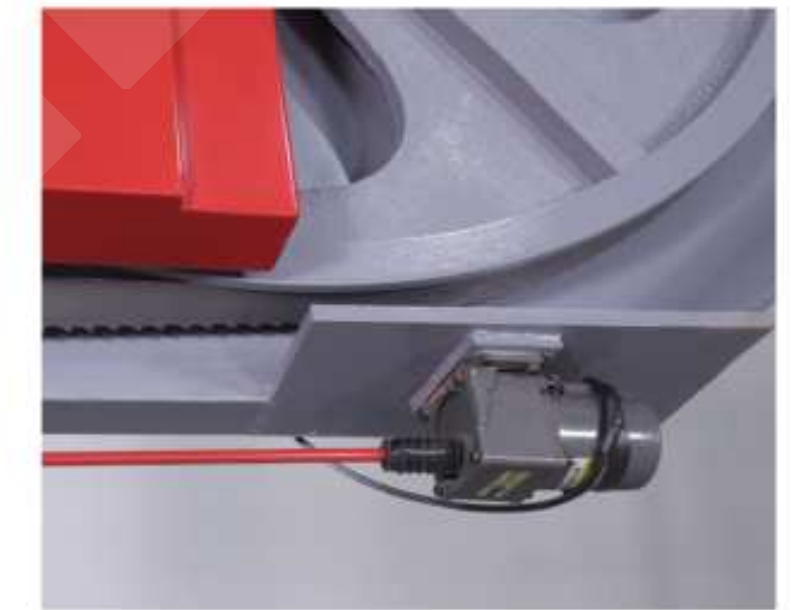
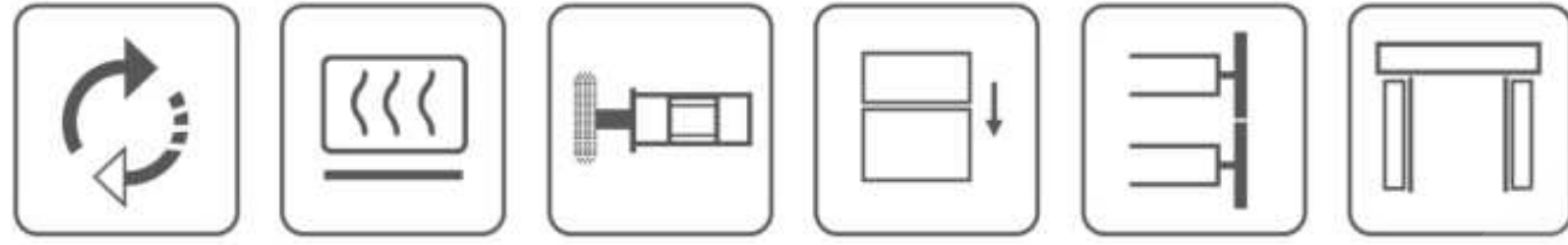

CUTTING CAPACITY	1200X1400MM	SINGLE FEEDING LENGTH	1200MM
BLADE SIZE	67X1.6X11880MM	MINIMUM CLAMPING DISTANCE	800MM
BLADE SPEED	10-60(变频)M/MIN	DISTANCE BETWEEN FRONT AND REAR JAWS	440MM
MAIN MOTOR	15KW 6级	WEIGHT	12200KG
COOLING MOTOR	0.09KW	MACHINE SIZE	5300X2300X3200MM
HYDRAULIC MOTOR	3.75KW	ROLLER TABLE SIZE (L*W*H)	大2125X1300 / 小550X1300MM